

XRAY X10

1/10 PAN CAR
EUROPEAN CHAMPION
PLATFORM



INSTRUCTION
MANUAL

MADE IN
EUROPE

X10'16



BEFORE YOU START

The X10 is a high-competition, high-quality, 1/10-pan car intended for persons aged 16 years and older with previous experience building and operating RC model racing cars. This is not a toy; it is a precision racing model. This model racing car is not intended for use by beginners, inexperienced customers, or by children without direct supervision of a responsible, knowledgeable adult. If you do not fulfill these requirements, please return the kit in unused and unassembled form back to the shop where you have purchased it.

Before building and operating your X10, YOU MUST read through all of the operating instructions and instruction manual and fully understand them to get the maximum enjoyment and prevent unnecessary damage. Read carefully and

CUSTOMER SUPPORT

We have made every effort to make these instructions as easy to understand as possible. However, if you have any difficulties, problems, or questions, please do not hesitate to contact the XRAY support team at info@teamxray.com. Also, please visit our Web site at www.teamxray.com to find the latest updates, set-up information, option parts, and many other goodies. We pride ourselves on taking excellent care of our customers.

You can join thousands of XRAY fans and enthusiasts in our online community at: www.teamxray.com

fully understand the instructions before beginning assembly.

Make sure you review this entire manual, download and use set-up book from the web, and examine all details carefully. If for some reason you decide The X10 is not what you wanted or expected, do not continue any further. Your hobby dealer cannot accept your X10 kit for return or exchange after it has been partially or fully assembled.

Contents of the box may differ from pictures. In line with our policy of continuous product development, the exact specifications of the kit may vary without prior notice.

XRAY Europe

K Vystavisku 6992
91101 Trenčín
Slovakia, EUROPE
Phone: 421-32-7401100
Fax: 421-32-7401109
E-mail: info@teamxray.com

XRAY USA

RC America, 2030 Century Center Blvd #15
Irving, TX 75062
USA
Phone: (800) 519-7221 * (214) 744-2400
Fax: (214) 744-2401
E-mail: xray@rcamerica.com

Failure to follow these instructions will be considered as abuse and/or neglect.

SAFETY PRECAUTIONS

Contains:

LEAD (CAS 7439-92-1) ANTIMONY (CAS 7440-36-0)

WARNING: This product contains a chemical known to the state of California to cause cancer and birth defects or other reproductive harm.

CAUTION: CANCER HAZARD

Contains lead, a listed carcinogen. Lead is harmful if ingested. Wash thoroughly after using. DO NOT use product while eating, drinking or using tobacco products. May cause chronic effects to gastrointestinal tract, CNS, kidneys, and blood. MAY CAUSE BIRTH DEFECTS.

When building, using and/or operating this model always wear protective glasses and gloves.

Take appropriate safety precautions prior to operating this model. You are responsible for this model's assembly and safe operation! Please read the instruction manual before building and operating this model and follow all safety precautions. Always keep the instruction manual at hand for quick reference, even after completing the assembly. Use only genuine and original authentic XRAY parts for maximum performance. Using any third party parts on this model will void guaranty immediately.

Improper operation may cause personal and/or property damage. XRAY and its distributors have no control over damage resulting from shipping, improper construction, or improper usage. XRAY assumes and accepts no responsibility for personal and/or property damages resulting from the use of improper building materials, equipment and operations. By purchasing any item produced by XRAY, the buyer expressly warrants that he/she is in compliance with all applicable federal, state and local laws and regulation regarding the purchase, ownership and use of the item. The buyer expressly agrees to indemnify and hold harmless XRAY for all claims resulting directly or indirectly from the purchase, ownership or use of the product. By the act of assembling or operating this product, the user accepts all resulting liability. If the buyer is not prepared to accept this liability, then he/she should return this kit in new, unassembled, and unused condition to the place of purchase.



IMPORTANT NOTES - GENERAL

- This product is not suitable for children under 16 years of age without the direct supervision of a responsible and knowledgeable adult.
- Carefully read all manufacturers warnings and cautions for any parts used in the construction and use of your model.
- Assemble this kit only in places away from the reach of very small children.
- First-time builders and users should seek advice from people who have building experience in order to assemble the model correctly and to allow the model to reach its performance potential.
- Exercise care when using tools and sharp instruments.
- Take care when building, as some parts may have sharp edges.
- Keep small parts out of reach of small children. Children must not be allowed to put any parts in their mouth, or pull vinyl bag over their head.
- Read and follow instructions supplied with paints and/or cement, if used (not included in kit).
- Immediately after using your model, do NOT touch equipment on the model such as the motor and speed controller, because they generate high temperatures. You may seriously burn yourself seriously touching them.
- Follow the operating instructions for the radio equipment at all times.
- Do not put fingers or any objects inside rotating and moving parts, as this may cause damage or serious injury as your finger, hair, clothes, etc. may get caught.
- Be sure that your operating frequency is clear before turning on or running your model, and never share the same frequency with somebody else at the same time. Ensure that others are aware of the operating frequency you are using and when you are using it.
- Use a transmitter designed for ground use with RC cars. Make sure that no one else is using the same frequency as yours in your operating area. Using the same frequency at the same time, whether it is driving, flying or sailing, can cause loss of control of the RC model, resulting in a serious accident.
- Always turn on your transmitter before you turn on the receiver in the car. Always turn off the receiver before turning your transmitter off.
- Keep the wheels of the model off the ground when checking the operation of the radio equipment.
- Disconnect the battery pack before storing your model.
- When learning to operate your model, go to an area that has no obstacles that can damage your model if your model suffers a collision.
- Remove any sand, mud, dirt, grass or water before putting your model away.
- If the model behaves strangely, immediately stop the model, check and clear the problem.
- To prevent any serious personal injury and/or damage to property, be responsible when operating all remote controlled models.
- The model car is not intended for use on public places and roads or areas where its operation can conflict with or disrupt pedestrian or vehicular traffic.
- Because the model car is controlled by radio, it is subject to radio interference from many sources that are beyond your control. Since radio interference can cause momentary loss of control, always allow a safety margin in all directions around the model in order to prevent collisions.
- Do not use your model:
 - Near real cars, animals, or people that are unaware that an RC car is being driven.
 - In places where children and people gather
 - In residential districts and parks
 - In limited indoor spaces
 - In wet conditions
 - In the street
 - In areas where loud noises can disturb others, such as hospitals and residential areas.
 - At night or anytime your line of sight to the model may be obstructed or impaired in any way.

To prevent any serious personal injury and/or damage to property, please be responsible when operating all remote controlled models.



IMPORTANT NOTES - ELECTRICAL

- Insulate any exposed electrical wiring (using heat shrink tubing or electrical tape) to prevent dangerous short circuits. Take maximum care in wiring, connecting and insulating cables. Make sure cables are always connected securely. Check connectors for if they become loose. And if so, reconnect them securely. Never use R/C models with damaged wires. A damaged wire is extremely dangerous, and can cause short-circuits resulting in fire. Please have wires repaired at your local hobby shop.
- Low battery power will result in loss of control. Loss of control can occur due to a weak battery in either the transmitter or the receiver. Weak running battery may also result in an out of control car if your car's receiver power is supplied by the running battery. Stop operation immediately if the car starts to slow down.
- When not using RC model, always disconnect and remove battery.
- Do not disassemble battery or cut battery cables. If the running battery short-circuits, approximately 300W of electricity can be discharged, leading to fire or burns. Never disassemble battery or cut battery cables.
- Use a recommended charger for the receiver and transmitter batteries and follow the instructions correctly. Over-charging, incorrect charging, or using inferior chargers can cause the batteries to become dangerously hot.

Recharge battery when necessary. Continual recharging may damage battery and, in the worst case, could build up heat leading to fire. If battery becomes extremely hot during recharging, please ask your local hobby shop for check and/or repair and/or replacement.

- Regularly check the charger for potential hazards such as damage to the cable, plug, casing or other defects. Ensure that any damage is rectified before using the charger again. Modifying the charger may cause short-circuit or overcharging leading to a serious accident. Therefore do not modify the charger.
- Always unplug charger when recharging is finished.
- Do not recharge battery while battery is still warm. After use, battery retains heat. Wait until it cools down before charging.
- Do not allow any metal part to short circuit the receiver batteries or other electrical/electronic device on the model.
- Immediately stop running if your RC model gets wet as may cause short circuit.
- Please dispose of batteries responsibly. Never put batteries into fire.

R/C & BUILDING TIPS

- Make sure all fasteners are properly tightened. Check them periodically.
- Make sure that chassis screws do not protrude from the chassis.
- For the best performance, it is very important that great care is taken to ensure the free movement of all parts.
- Clean all ball-bearings so they move very easily and freely.
- Tap or pre-thread the plastic parts when threading screws.
- Self-tapping screws cut threads into the parts when being tightened. Do not use excessive force when tightening the self-tapping screws because you may strip out the thread in the plastic. We recommended you stop tightening a screw when you feel some resistance.
- Ask your local hobby shop for any advice.

Please support your local hobby shop. We at XRAY Model Racing Cars support all local hobby dealers. Therefore we ask you, if at all possible, to purchase XRAY products at your hobby dealer and give them your support like we do. If you have difficulty finding XRAY products, please check out www.teamxray.com to get advice, or contact us via email at info@teamxray.com, or contact the XRAY distributor in your country.

WARRANTY

XRAY guarantees this model kit to be free from defects in both material and workmanship within 30 days of purchase. The total monetary value under warranty will in no case exceed the cost of the original kit purchased. This warranty does not cover any components damaged by use or modification or as a result of wear. Part or parts missing from this kit must be reported within 30 days of purchase. No part or parts will be sent under warranty without proof of purchase. Should you find a defective or missing part, contact the local distributor. Service and customer support will be provided through local hobby store where you have purchased the kit, therefore make sure to purchase any XRAY products at your local hobby store. This model racing car is considered to be a high-performance racing vehicle. As such this vehicle will be used in an extreme range of conditions and situations, all which may cause premature wear or failure of any component. XRAY has no control over usage of vehicles once they leave the dealer, therefore XRAY can only offer warranty against all manufacturer's defects in materials, workmanship, and assembly at point of sale and before use. No warranties are expressed or implied that cover damage caused by what is considered normal use, or cover or imply how long any model cars' components or electronic components will last before requiring replacement.

Due to the high performance level of this model car you will need to periodically maintain and replace consumable components. Any and all warranty coverage will not cover replacement of any part or component damaged by neglect, abuse, or improper or unreasonable use. This includes but is not limited to

damage from crashing, chemical and/or water damage, excessive moisture, improper or no maintenance, or user modifications which compromise the integrity of components. Warranty will not cover components that are considered consumable on RC vehicles. XRAY does not pay nor refund shipping on any component sent to XRAY or its distributors for warranty. XRAY reserves the right to make the final determination of the warranty status of any component or part.

Limitations of Liability

XRAY makes no other warranties expressed or implied. XRAY shall not be liable for any loss, injury or damages, whether direct, indirect, special, incidental, or consequential, arising from the use, misuse, or abuse of this product and/or any product or accessory required to operate this product. In no case shall XRAY's liability exceed the monetary value of this product.

Take adequate safety precautions prior to operating this model. You are responsible for this model's assembly and safe operation.

Disregard of the any of the above cautions may lead to accidents, personal injury, or property damage. XRAY MODEL RACING CARS assumes no responsibility for any injury, damage, or misuse of this product during assembly or operation, nor any addictions that may arise from the use of this product.

All rights reserved.

QUALITY CERTIFICATE

XRAY MODEL RACING CARS uses only the highest quality materials, the best compounds for molded parts and the most sophisticated manufacturing processes of TQM (Total Quality Management). We guarantee that all parts of a newly-purchased kit are manufactured with the highest regard to quality. However, due to the many factors inherent in model racecar competition, we cannot guarantee

any parts once you start racing the car. Products which have been worn out, abused, neglected or improperly operated will not be covered under warranty. We wish you enjoyment of this high-quality and high-performance RC car and wish you best success on the track!

In line with our policy of continuous product development, the exact specifications of the kit may vary. In the unlikely event of any problems with your new kit, you should contact the model shop where you purchased it, quoting the part number.

We do reserve all rights to change any specification without prior notice. All rights reserved.

X10'16

SYMBOLS USED

Part bags used 	Assemble in the specified order 	Assemble left and right sides the same way 	Pay attention here 	Assemble as many times as specified (here twice) 	Cut 	Apply CA glue
Apply oil 	Apply grease 	Ensure smooth non-binding movement 	Tighten screw gently 	Detail view 	Assembly view 	Follow Set-Up Book

TOOLS REQUIRED

HUDY TOOLS: Allen: 1.5mm Allen: 2.0mm Allen: 2.5mm Allen: 3.0mm Socket: 5.5mm					Turnbuckle Wrench 4mm (HUDY #181040) 	Turnbuckle Wrench 3mm (HUDY #181030)
Scissors (HUDY #188990) 	Combination Pliers (HUDY #189020) 	Side Cutters (HUDY #189010) 	Hobby Knife 	Sandpaper 	Reamer (HUDY #107600) or (HUDY #107601) 	

EQUIPMENT INCLUDED

HUDY Premium Silicone Oil 700cSt (#106370) Oil 10000cSt (#106510) 	Diff Grease (HUDY #106211)
---	-----------------------------------

NOT INCLUDED

SAMPLE OF OPTIONAL PARTS #37XXX OPTION 1 #37XXX OPTION 2 #37XXX OPTION 3	XRAY offers wide range of optional tuning parts which are listed in a table like this. Please refer to the exploded view of each main section to verify which part is included in the kit while all other parts are available only as optional parts and must be purchased separately.
--	--

EQUIPMENT REQUIRED

Transmitter 	Receiver 	Steering Servo 	Electric Motor & Pinion Gear and Setscrew 	Bearing Oil (HUDY #106230) 	Speed Controller 	Tire Truer (HUDY #102003)
Body Shell 	LiPo Battery 	Lexan™ Paint 	Battery Charger 	Fibre Tape (HUDY #107870) 	Double-sided Tape 	Tires

GRAPHITE PARTS PREPARATION

PREPARE ALL GRAPHITE PARTS

To protect and seal edges of graphite parts, sand edges smooth and then apply CA glue.

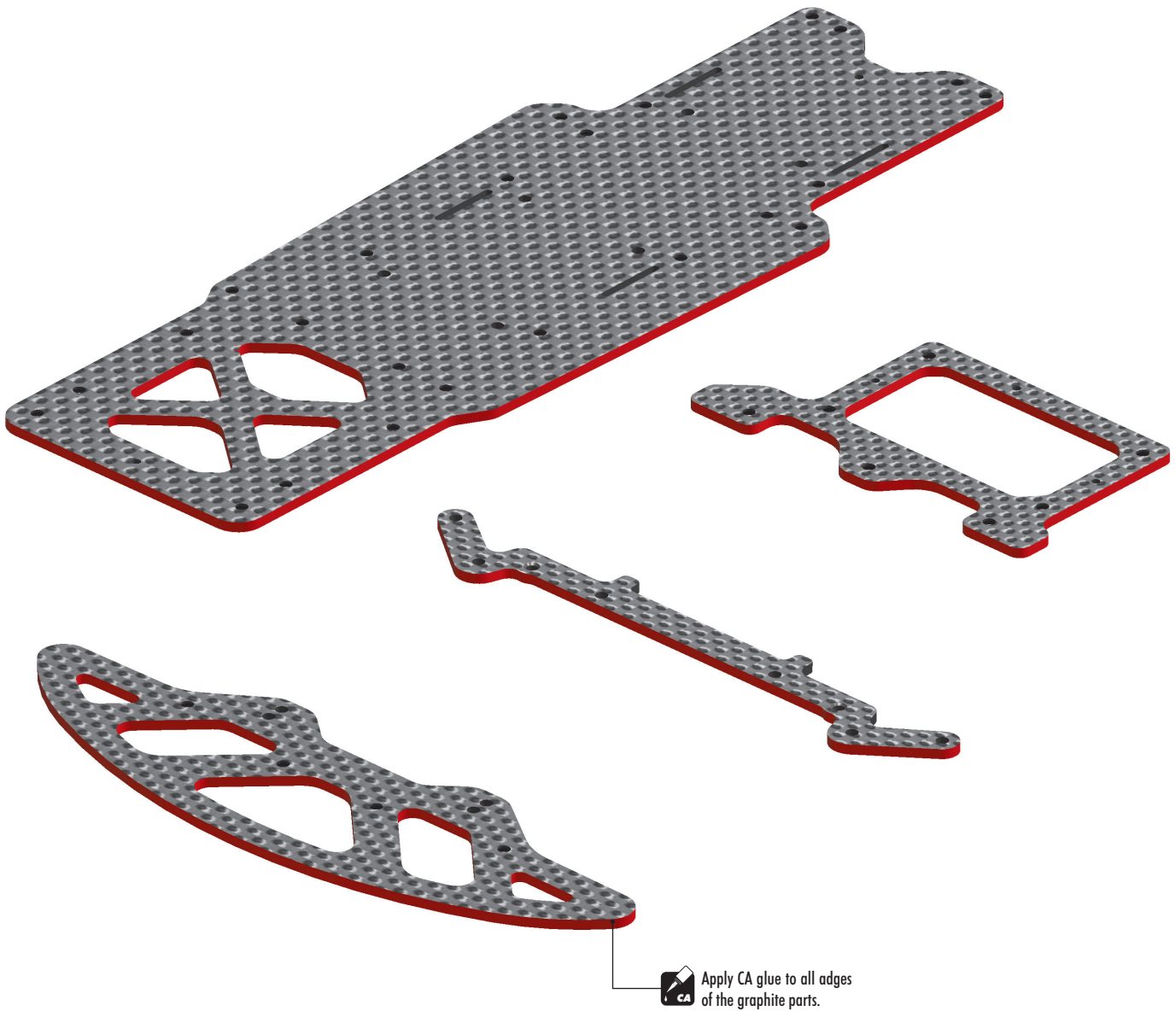
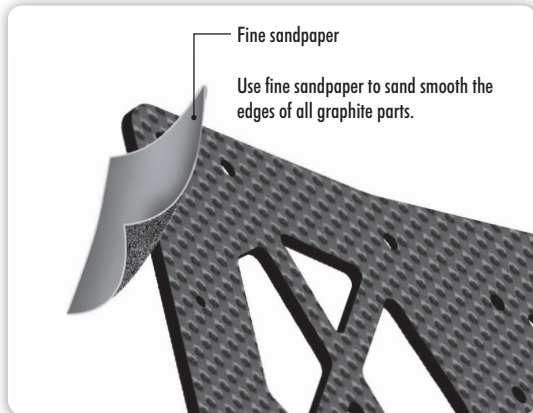

1. FRONT SUSPENSION



UPPER ARM MOUNTS		
#372010	R - MEDIUM	INCLUDED
#372011	R - HARD	OPTION
#372012	R - GRAPHITE	OPTION
#372020	L - MEDIUM	INCLUDED
#372021	L - HARD	OPTION
#372022	L - GRAPHITE	OPTION

UPPER SUSPENSION ARMS		
#372130	MEDIUM	INCLUDED
#372131	HARD	OPTION

LOWER SUSPENSION ARMS		
#372112	R - HARD	INCLUDED
#372113	R - GRAPHITE	OPTION
#372122	L - HARD	INCLUDED
#372123	L - GRAPHITE	OPTION

FRONT COIL SPRINGS - SOFT		
#372176	C=1.5 - GOLD	OPTION
#372177	C=2.0 - SILVER	OPTION
#372178	C=2.5 - BLACK	OPTION
#372179	C=3.0 - GREY	OPTION

FRONT COIL SPRINGS		
#372180	C=3.5 - GOLD	INCLUDED
#372181	C=4.0 - SILVER	OPTION
#372182	C=5.0 - BLACK	OPTION
#372183	C=5.5 - GREY	OPTION

ALU ECCENTRIC BUSHINGS		
#372316-0	0mm	INCLUDED
#372317-0	0.5mm	OPTION
#372318-0	1.0mm	OPTION

M3 NUTS		
#960030	STEEL	INCLUDED
#960031	ALU	OPTION
#296530-0	ALU	OPTION

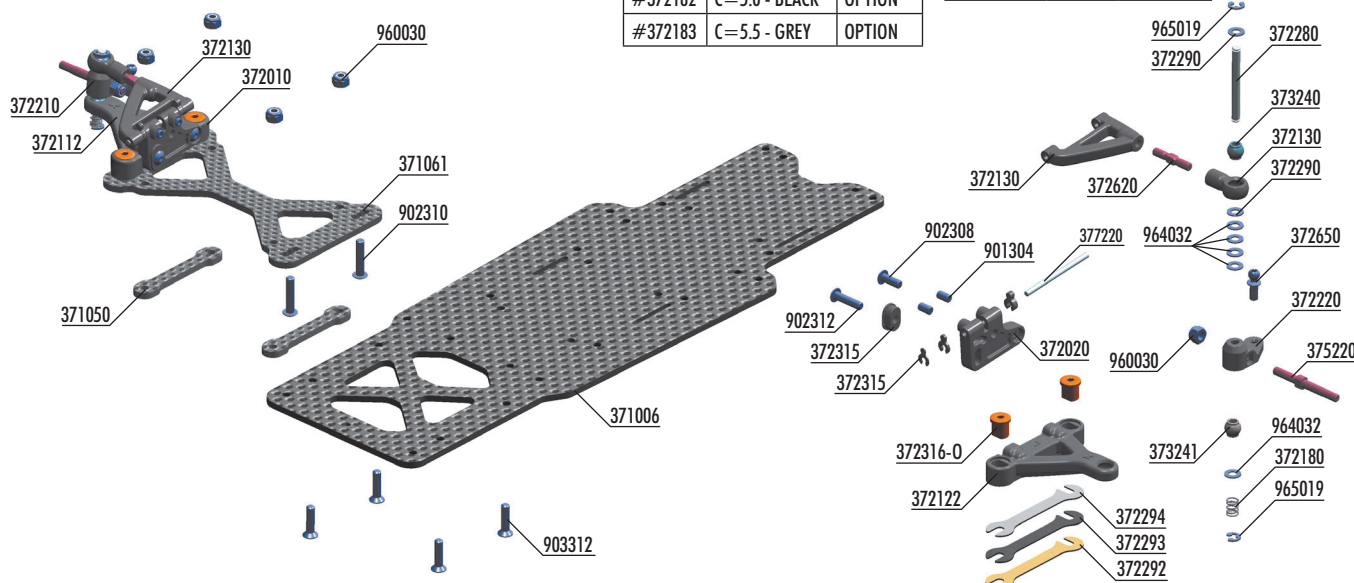

BAG

01

- 371006 X10*16 CHASSIS - 2.5MM GRAPHITE
- 371050 X10 GRAPHITE 2.5MM MOUNTING PLATE RISERS (2)
- 371061 X10 GRAPHITE 2.5MM ARM MOUNT PLATE
- 372010 COMPOSITE FRONT UPPER ARM MOUNT - RIGHT
- 372020 COMPOSITE FRONT UPPER ARM MOUNT - LEFT
- 372112 SUSPENSION ARM - FRONT LOWER - RIGHT - HARD
- 372122 SUSPENSION ARM - FRONT LOWER - LEFT - HARD
- 372130 FRONT UPPER SUSPENSION ARM & BALL JOINT
- 372180 FRONT COIL SPRING 3.6x6x0.5MM; C=3.5 - GOLD (2)
- 372210 COMPOSITE STEERING BLOCK - RIGHT
- 372220 COMPOSITE STEERING BLOCK - LEFT
- 372280 KING PIN (2)
- 372290 ALU SHIM 3.2x4.8x0.5 (4)
- 372292 STEEL SHIM 0.2MM - SILVER (2)
- 372293 STEEL SHIM 0.4MM - BLACK (2)
- 372294 STEEL SHIM 0.6MM - GOLD (2)
- 372315 COMPOSITE ECCENTRIC BUSHINGS + CASTER CLIPS (2)

- 372316-0 ALU ECCENTRIC BUSHING 0.0MM - ORANGE (2)
- 372620 ADJ. TURNBUCKLE M3x17 MM - HUDY SPRING STEEL™ (2)
- 372650 BALL-END 4.2MM - THREADED - HUDY SPRING STEEL™ (2)
- 373240 PIVOTBALL UNIVERSAL 6.0 MM - HUDY SPRING STEEL™ (2)
- 373241 COMPOSITE PIVOTBALL UNIVERSAL 6.0 MM (2)
- 375220 FRONT WHEEL AXLE - HUDY SPRING STEEL™ (2)
- 377220 FRONT UPPER PIVOT PIN 2x31MM (2)
- 901304 HEX SCREW SB M3x4 (10)
- 902308 HEX SCREW SH M3x8 (10)
- 902310 HEX SCREW SH M3x10 (10)
- 902312 HEX SCREW SH M3x12 (10)
- 903312 HEX SCREW SFH M3x12 (10)
- 960030 NUT M3 (10)
- 964032 WASHER S 3.2 x 4.8 x 0.2 (10)
- 965019 E-CLIP 1.9 (10)

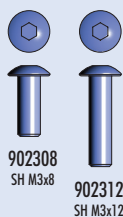

2x **L=R**

REACTIVE CASTER SETTING	
	= 2.5°
	= 5° INITIAL SETTING
	= 7.5°

Use same bushings in left and right sides.



UPPER ARM POSITION ADJUSTMENT SHIMS

- #303121-0 SHIM 3x6x0.5mm
- #373120-0 SHIM 5.3x7.8x0.5mm

The shims influence the camber gain change.

MORE shims = less camber gain, reduced initial steering, reduced steering sensitivity (less twitchy).

LESS shims = more camber gain, increased initial steering, increased steering sensitivity.

Instead of M3x8 screw must be used M3x10 screw. Use same shim thickness on both left & right sides.



LOWER SUSPENSION ARMS

#372112	R - HARD	INCLUDED
#372113	R - GRAPHITE	OPTION
#372122	L - HARD	INCLUDED
#372123	L - GRAPHITE	OPTION

UPPER ARM MOUNTS

#372010	R - MEDIUM	INCLUDED
#372011	R - HARD	OPTION
#372012	R - GRAPHITE	OPTION
#372020	L - MEDIUM	INCLUDED
#372021	L - HARD	OPTION
#372022	L - GRAPHITE	OPTION



CASTER

FRONT SUSPENSION

2x L=R

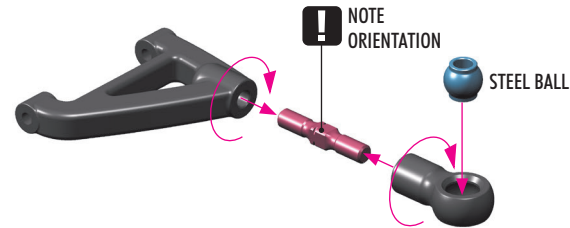

OPTION

UPPER SUSPENSION ARMS

#372130	MEDIUM	INCLUDED
#372131	HARD	OPTION

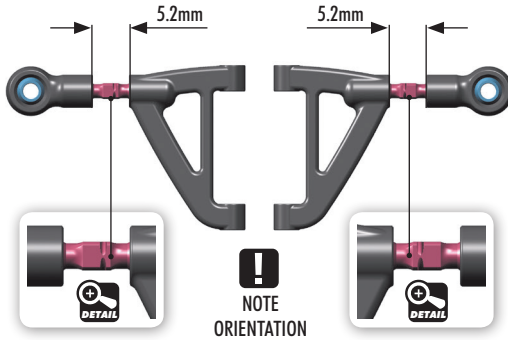

SET-UP BOOK
CAMBER

2x L=R

901304
SB M3x4

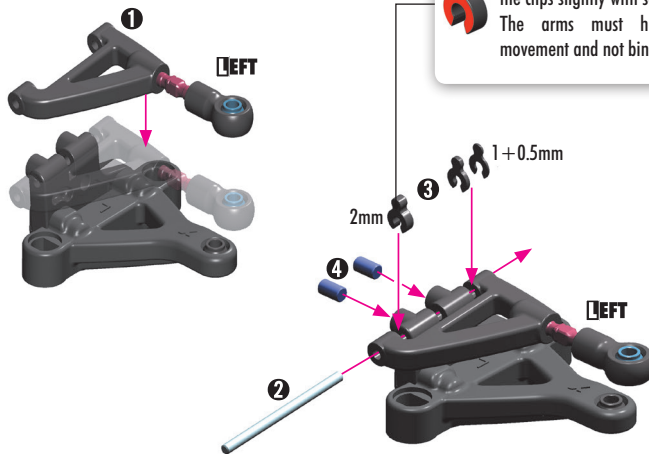

If the arm does not have enough play, remove the clips and thin the clips slightly with sandpaper. The arms must have free movement and not bind.

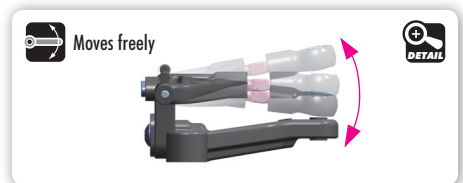
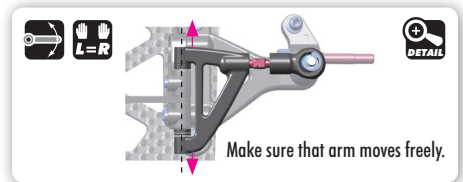

SET-UP BOOK
CASTER

2x L=R

960030
N M3

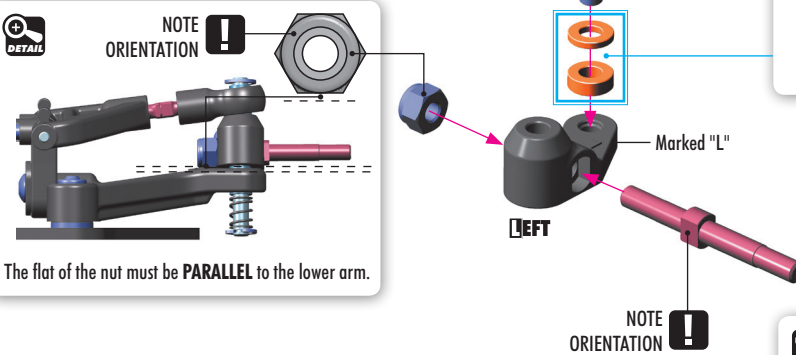

OPTION The thickness of shims changes the steering linkage angle. Thicker shims gives decreased in-corner steering, but car becomes easier to drive.
#303122-0 SHIM 3x6x1
#303123-0 SHIM 3x6x2

M3 NUTS			
OPTION	#960030	STEEL	SILVER INCLUDED
	#960031	ALU	SILVER OPTION
	#296530-0	ALU	ORANGE OPTION

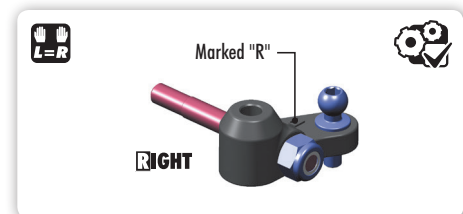

FRONT SUSPENSION

372290
S 3.2x4.8x0.5

964032
S 3.2x4.8x0.2

965019
C 1.9

2x L=R

LOW traction & bumpy track
10K cSt (#106510 HUDY)

HIGH traction & smooth track
30K cSt (#106530 HUDY)

use HUDY Silicone Oil

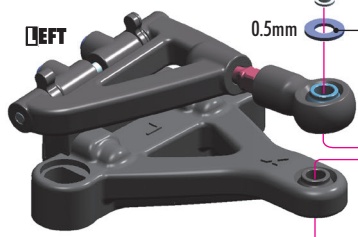

The thickness of shims used affects the ride height of the car, so determine the proper amount of shimming based on tire diameter.

FRONT RIDE HEIGHT ADJUSTMENT

INITIAL SETTING

- above upper arm (0.5mm)
- above steering block (1.3mm)
- below steering block (0.2mm)

OPTION

FRONT COIL SPRINGS - SOFT		
#372176	C=1.5 - GOLD	OPTION
#372177	C=2.0 - SILVER	OPTION
#372178	C=2.5 - BLACK	OPTION
#372179	C=3.0 - GREY	OPTION

FRONT COIL SPRINGS		
#372180	C=3.5 - GOLD	INCLUDED
#372181	C=4.0 - SILVER	OPTION
#372182	C=5.0 - BLACK	OPTION
#372183	C=5.5 - GREY	OPTION

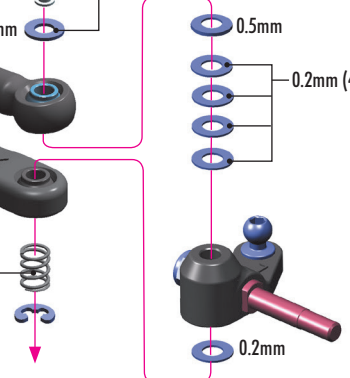

SET-UP BOOK
RIDE HEIGHT

903312
SFH M3x12

960030
N M3

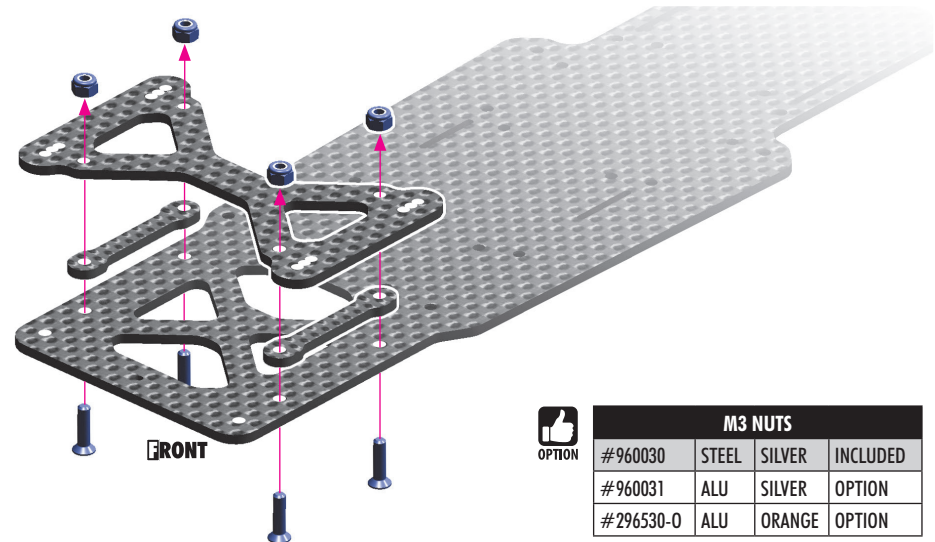

OPTION

M3 NUTS			
#960030	STEEL	SILVER	INCLUDED
#960031	ALU	SILVER	OPTION
#296530-0	ALU	ORANGE	OPTION

2x L=R

The X10 has adjustable front track-width. There are 3 different bushings - 0mm centric (included in kit), or 0.5mm or 1.0mm eccentric (optional). Use the same bushing in front and rear, and also use the same orientation of the bushing on both right and left sides.

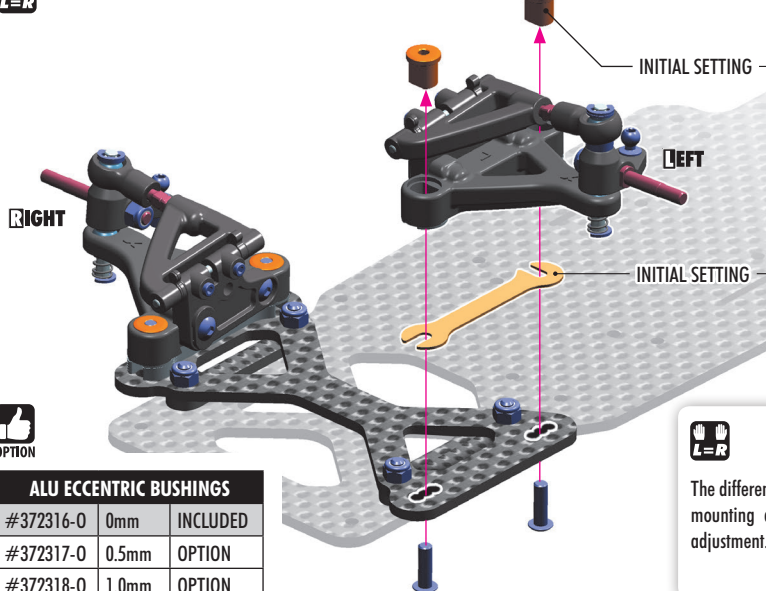

LEFT	+	RIGHT	=	TRACK-WIDTH
	-1mm			193mm
	-0.5mm			192mm
	0mm			191mm
	+0.5mm			190mm
	+1mm			189mm

Use the proper matching bushings to achieve the desired front track-width.

Use 0.6mm washer (#372294 - GOLD)

The number of washers used affects the ride height of the car, so determine the proper amount of shimming based on tire diameter.

OPTION

ALU ECCENTRIC BUSHINGS		
#372316-0	0mm	INCLUDED
#372317-0	0.5mm	OPTION
#372318-0	1.0mm	OPTION

L=R

The different holes for suspension mounting allows for wheelbase adjustment.

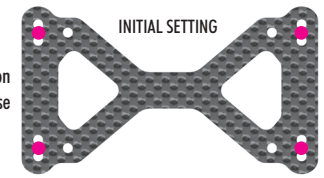

SET-UP BOOK
RIDE HEIGHT TRACK-WIDTH

3. REAR SUSPENSION

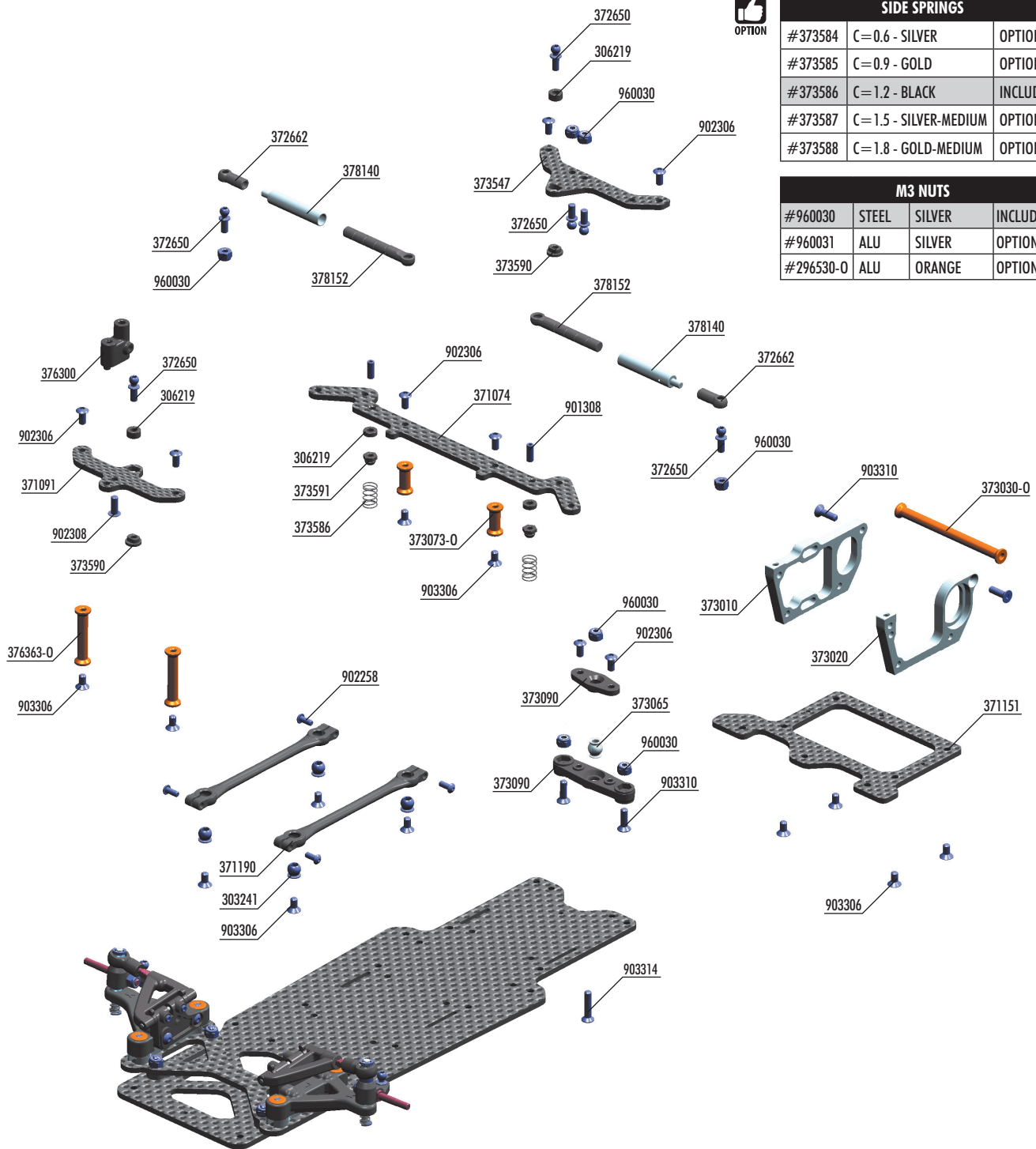

SIDE SPRINGS		
#373584	C=0.6 - SILVER	OPTION
#373585	C=0.9 - GOLD	OPTION
#373586	C=1.2 - BLACK	INCLUDED
#373587	C=1.5 - SILVER-MEDIUM	OPTION
#373588	C=1.8 - GOLD-MEDIUM	OPTION

M3 NUTS			
#960030	STEEL	SILVER	INCLUDED
#960031	ALU	SILVER	OPTION
#296530-0	ALU	ORANGE	OPTION

BAG

03

- | | | | |
|----------|--|----------|----------------------------------|
| 303241 | BALL UNIVERSAL 5.8 MM HEX (4) | 373590 | COMPOSITE SPRING HOLDER (2) |
| 306219 | COMPOSITE SET OF SERVO SHIMS (4) | 373591 | COMPOSITE SIDE SPRING HOLDER (2) |
| 371074 | X10'16 REAR BRACE - GRAPHITE 2.5MM | 376300 | COMPOSITE ANTENNA MOUNT |
| 371091 | X10 GRAPHITE PLATE FOR MOUNTS & ANTENNA HOLDER | 376363-0 | ALU MOUNT 28.5MM - ORANGE (2) |
| 371151 | X10'16 GRAPHITE 2.5MM REAR POD LOWER PLATE | 378140 | SIDE LINKAGE TUBE (2) |
| 371190 | COMPOSITE POD LINK (2) | 378152 | COMPOSITE SIDE LINKAGE SHAFT (2) |
| 372650 | BALL-END 4.2MM THREADED HUDY SPRING STEEL™ (2) | 901308 | HEX SCREW SB M3x8 (10) |
| 372662 | COMPOSITE BALL-JOINT 4.2 MM (4) | 902258 | HEX SCREW SH M2.5x8 (10) |
| 373010 | ALU REAR BULKHEAD - MOTOR (RIGHT) | 902306 | HEX SCREW SH M3x6 (10) |
| 373020 | ALU REAR BULKHEAD - LEFT | 902308 | HEX SCREW SH M3x8 (10) |
| 373030-0 | ALU REAR BULKHEAD BRACE | 903306 | HEX SCREW SFH M3x6 (10) |
| 373065 | PIVOT BALL - HUDY SPRING STEEL™ (2) | 903310 | HEX SCREW SFH M3x10 (10) |
| 373073-0 | ALU REAR BRACE MOUNT 16MM- ORANGE (2) | 903314 | HEX SCREW SFH M3x14 (10) |
| 373090 | COMPOSITE LOWER & UPPER PIVOT BRACE | 960030 | NUT M3 (10) |
| 373547 | X10'16 REAR POD UPPER PLATE - GRAPHITE 2.5MM | | |
| 373586 | SIDE SPRING C=1.2 - BLACK (2) | | |

REAR SUSPENSION



903306
SFH M3x6



903310
SFH M3x10

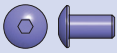
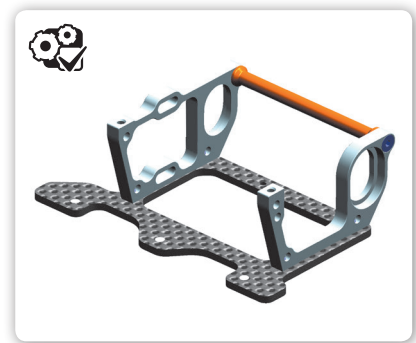
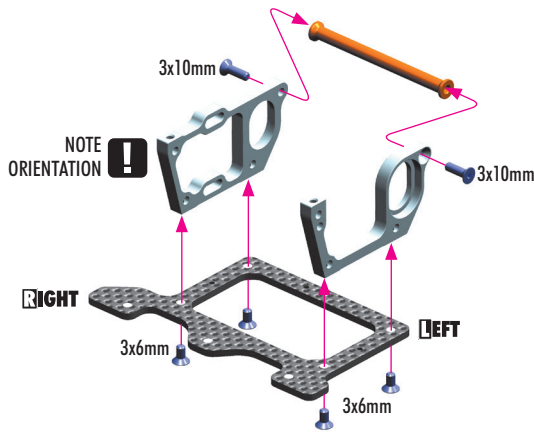

902306
SH M3x6

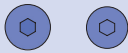
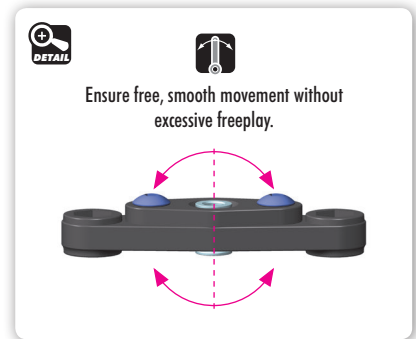
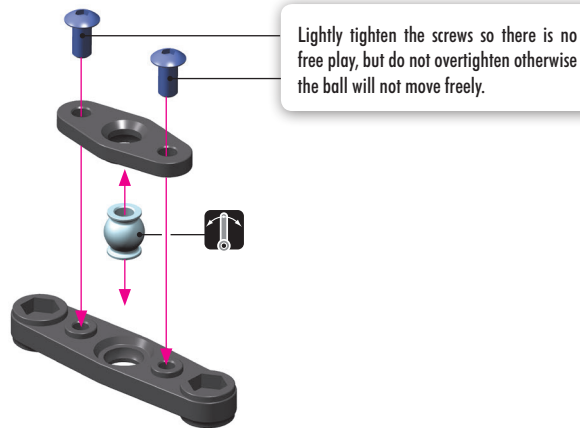

903310
SFH M3x10

903314
SFH M3x14



960030
N M3

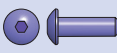
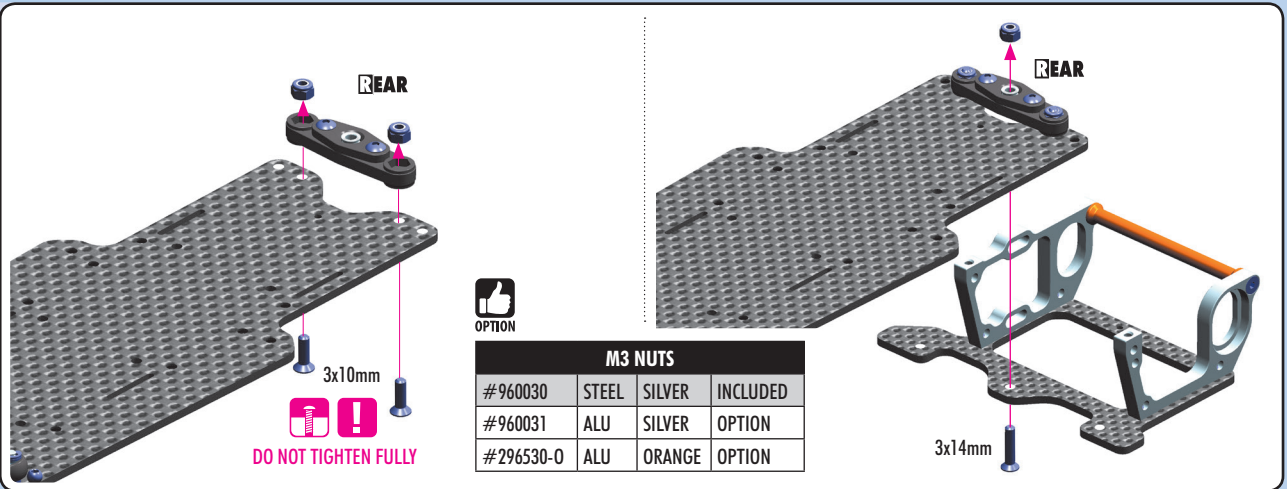

902258
SH M2.5x8

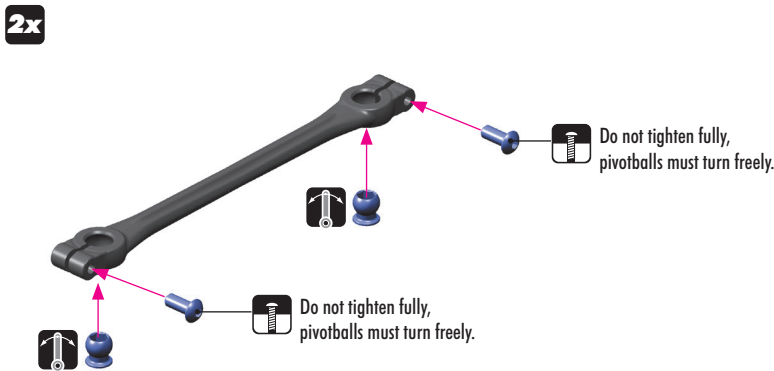

REAR SUSPENSION

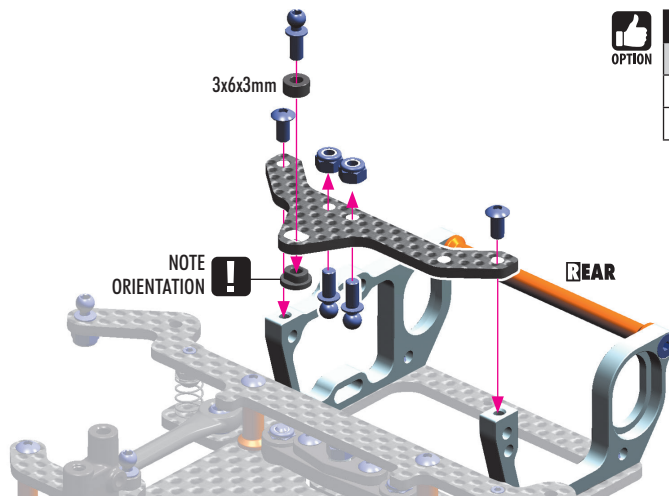
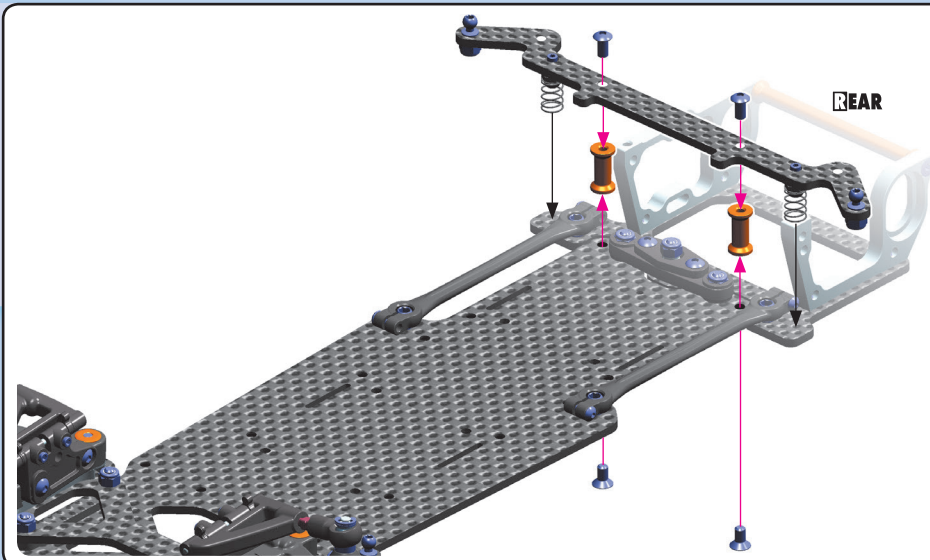
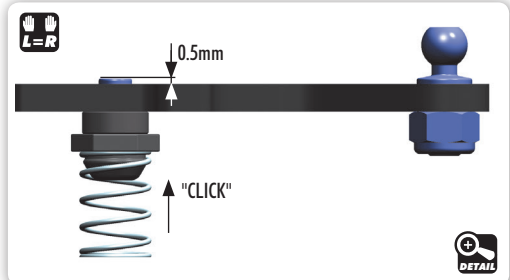
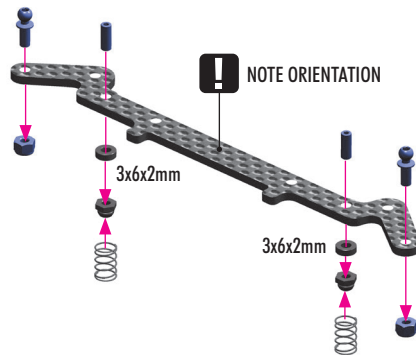
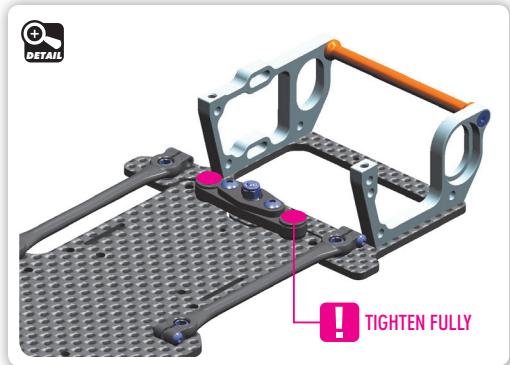
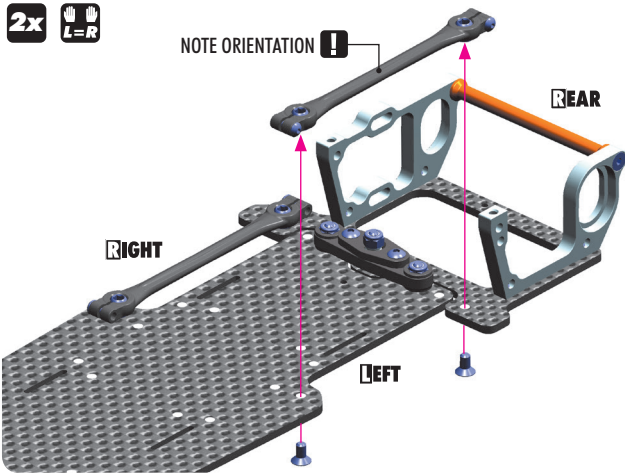

M3 NUTS			
#960030	STEEL	SILVER	INCLUDED
#960031	ALU	SILVER	OPTION
#296530-0	ALU	ORANGE	OPTION

REAR SUSPENSION



306219
SHIM 3x6x3

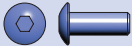

902308
SH M3x8

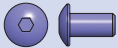

902306
SH M3x6



903306
SFH M3x6

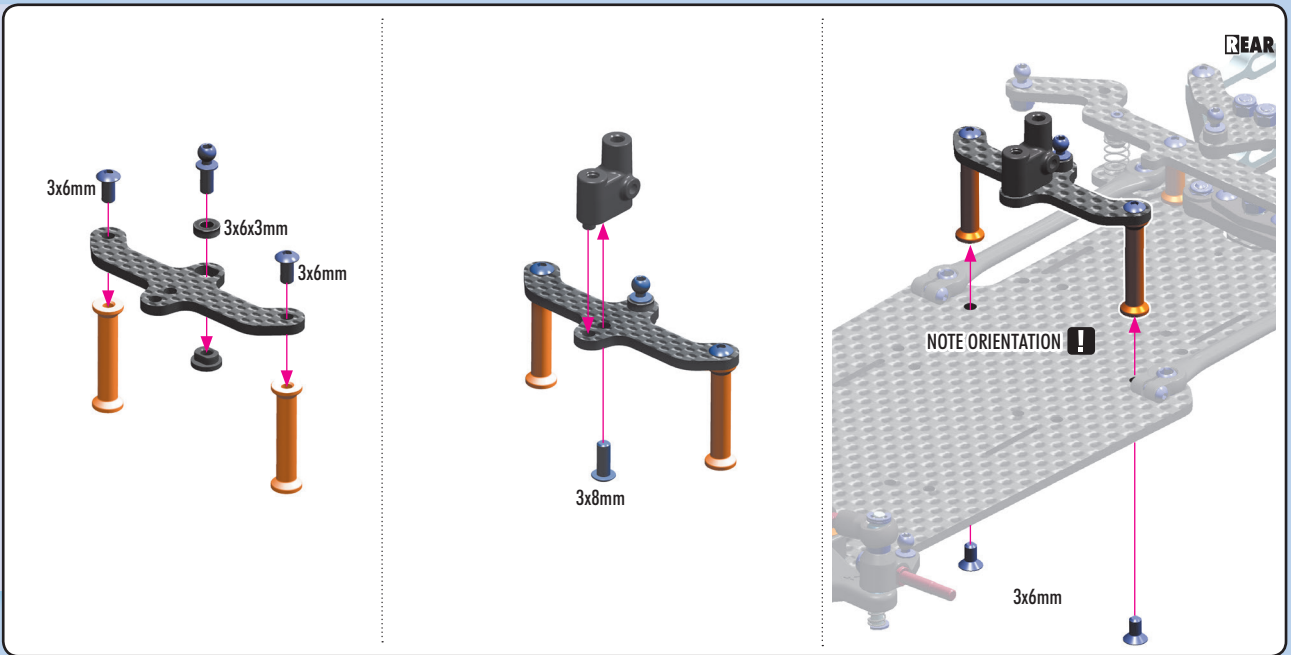

2x

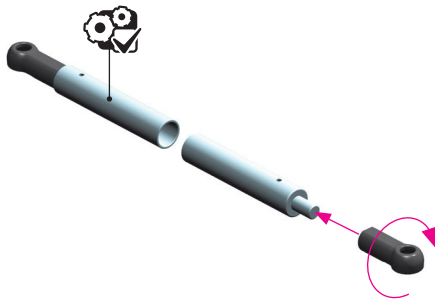

2x

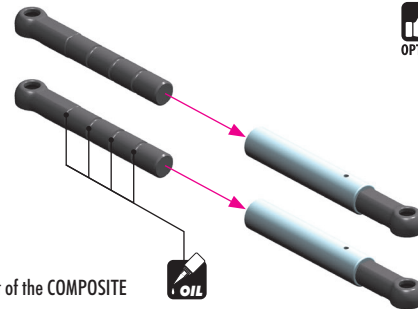

Add oil in each slot of the COMPOSITE side shock tubes.

NOTE:

Add oil only in the slots, not on the whole tube.
After assembling the side tubes, check for smooth operation.
It is very important to re-oil the side tubes, at least once per race day.
You may use different oil thicknesses depending on track conditions.

TIP

For HIGH grip	use SOFTER oils
For LOW grip or ASPHALT	use HARDER oils



HUDY OILS

#106410	1000cSt
#106420	2000cSt
#106430	3000cSt
#106450	5000cSt
#106460	6000cSt
#106470	7000cSt
#106480	8000cSt
#106510	10000cSt
#106515	15000cSt
#106520	20000cSt
#106530	30000cSt
#106540	40000cSt
#106550	50000cSt
#106560	60000cSt
#106580	80000cSt
#106610	100000cSt

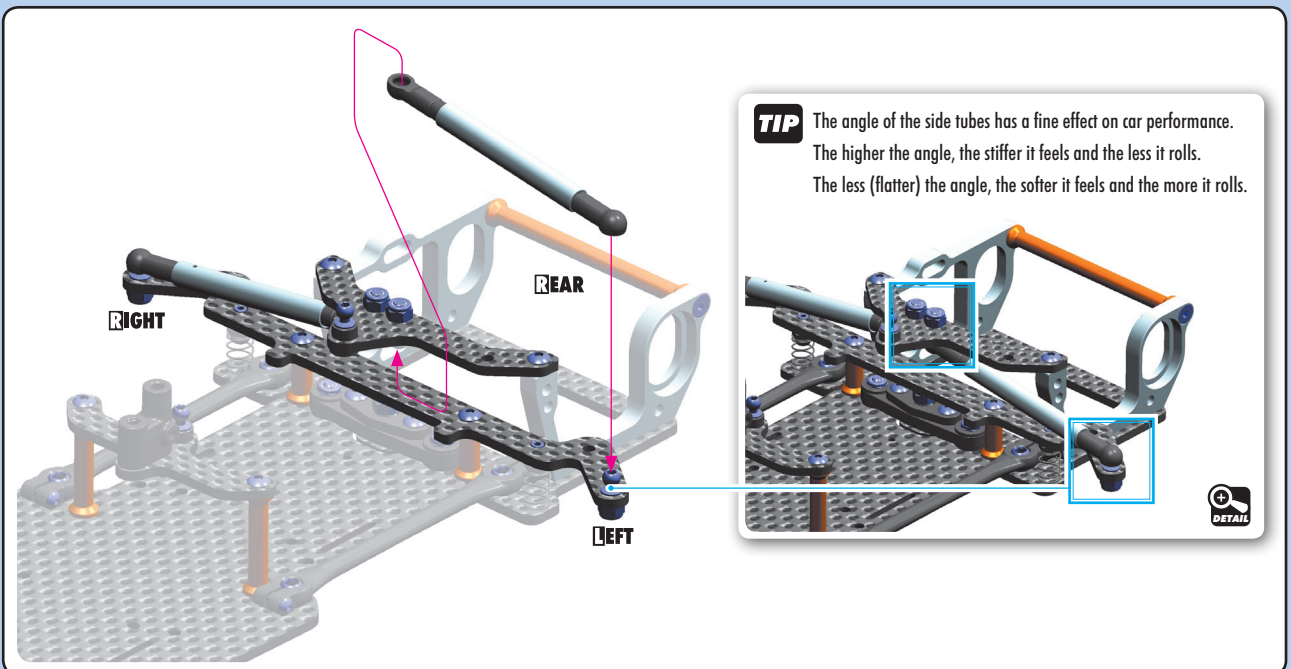

TIP

The angle of the side tubes has a fine effect on car performance.
The higher the angle, the stiffer it feels and the less it rolls.
The less (flatter) the angle, the softer it feels and the more it rolls.



4. BALL DIFFERENTIAL



OPTION

SPUR GEARS		
#375876	76T / 64P	OPTION
#375878	78T / 64P	OPTION
#375880	80T / 64P	OPTION
#375896	96T / 64P	INCLUDED

REAR AXLE SHAFTS		
#375010	GRAPHITE	OPTION
#375012	STEEL	INCLUDED

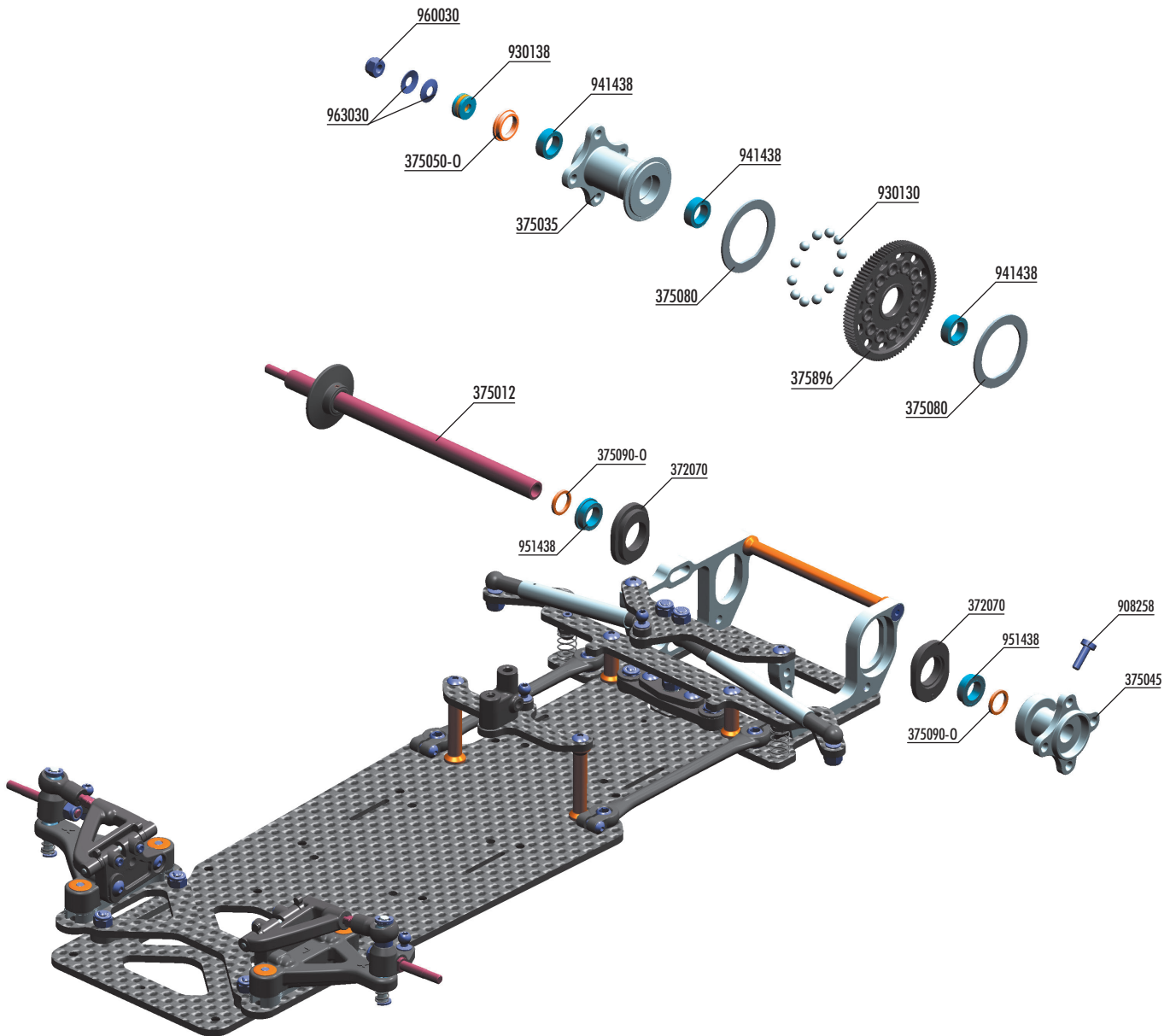

BAG

04

- 372070 COMPOSITE RIDE HEIGHT ADJUSTER SET (2)
- 375010 REAR AXLE SHAFT - GRAPHITE - V3 (OPTION)
- 375012 STEEL REAR AXLE SHAFT - HUDY SPRING STEEL™
- 375035 X10 ALU REAR WHEEL HUB - RIGHT
- 375045 X10 ALU REAR WHEEL HUB - LEFT
- 375050-0 ALU DIFF HUB - ORANGE
- 375080 D-LOCK DIFF PLATE (2)
- 375090-0 SET OF ALU SHIMS (0.5MM, 1.0MM, 2.0MM) - ORANGE
- 375896 COMPOSITE SPUR GEAR - 96T / 64P
- 908258 HEX SCREW SOCKET HEAD CAP M2.5x8 (10)

- 930130 CARBIDE BALL 3.175MM (12)
- 930138 CARBIDE BALL-BEARING AXIAL F3-8 3x8x3.5
- 930230 CERAMIC BALL 3.175MM (12) (OPTION)
- 930238 CERAMIC BALL-BEARING AXIAL F3-8 3x8x3.5 (OPTION)
- 941438 HIGH-SPEED BALL-BEARING 1/4"x3/8"x1/8" RUBBER SEALED (2)
- 951438 BALL-BEARING 1/4" x 3/8" x 1/8" FLANGED (2)
- 960030 NUT M3 (10)
- 963030 CONE WASHER ST 3x8x0.5 (10)

BALL DIFFERENTIAL



951438
BB 1/4"x3/8"x1/8"

2x
L=R

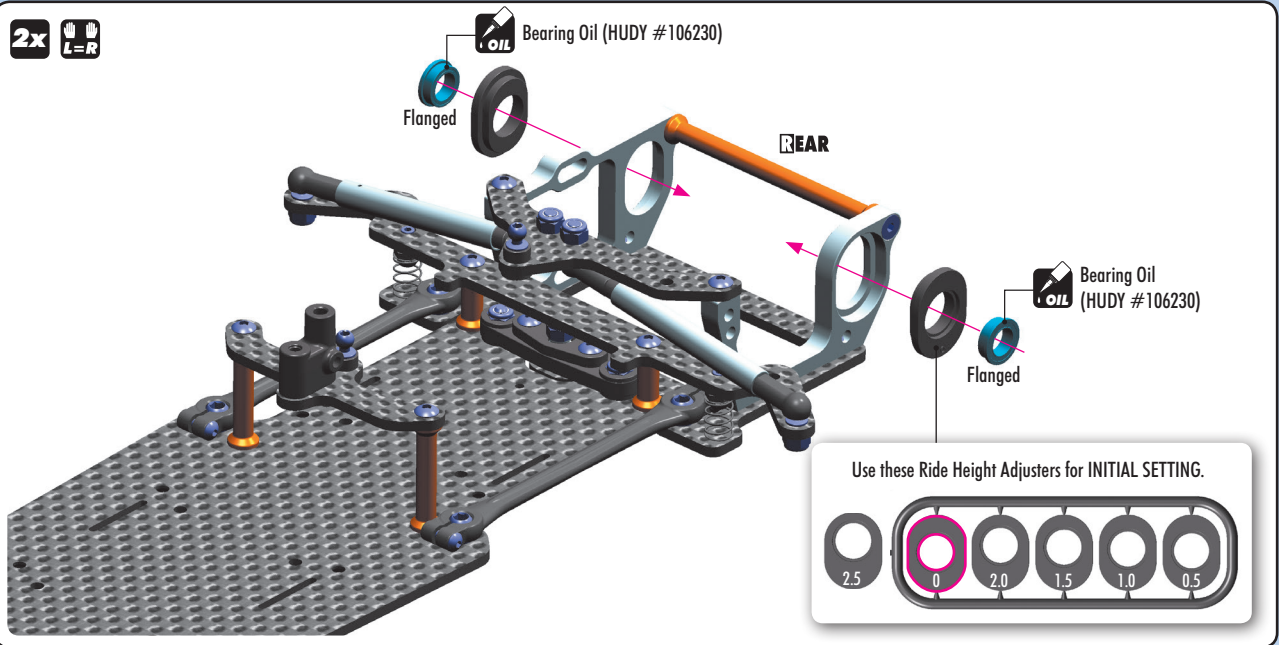

SET-UP BOOK

RIDE HEIGHT



375090-0
6.4x8.4x1.0

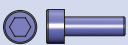

908258
SCH M2.5x8

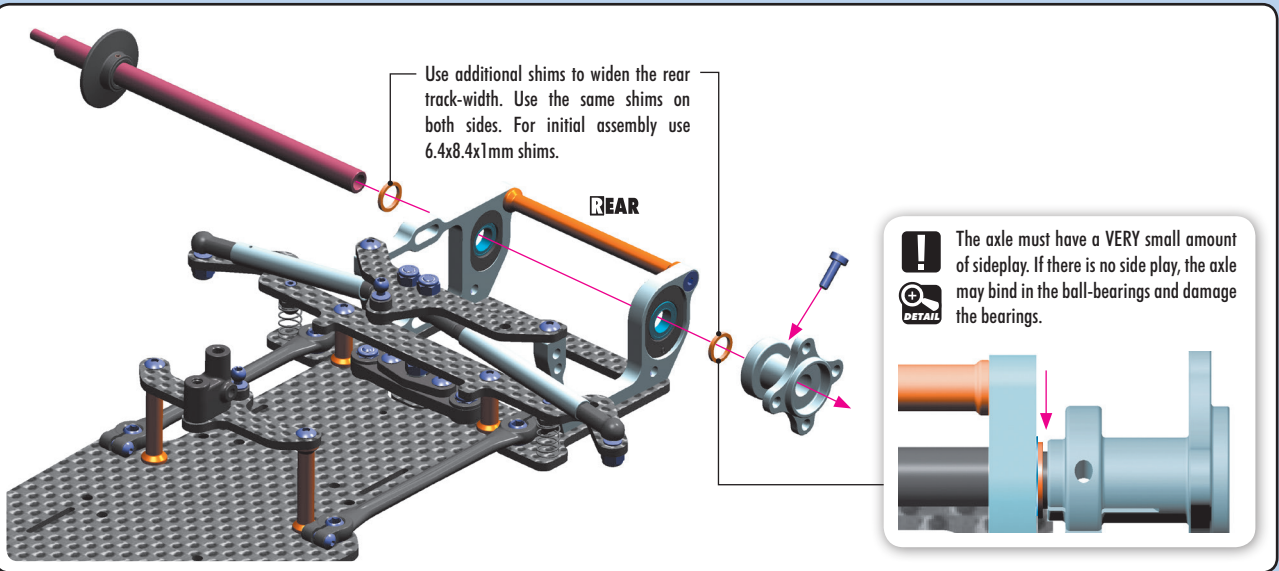

SET-UP BOOK

TRACK-WIDTH

930130
B 3.1



930138
BA 3x8



941438
BB 1/4"x3/8"x1/8"



963030
ST 3x8



960030
N M3

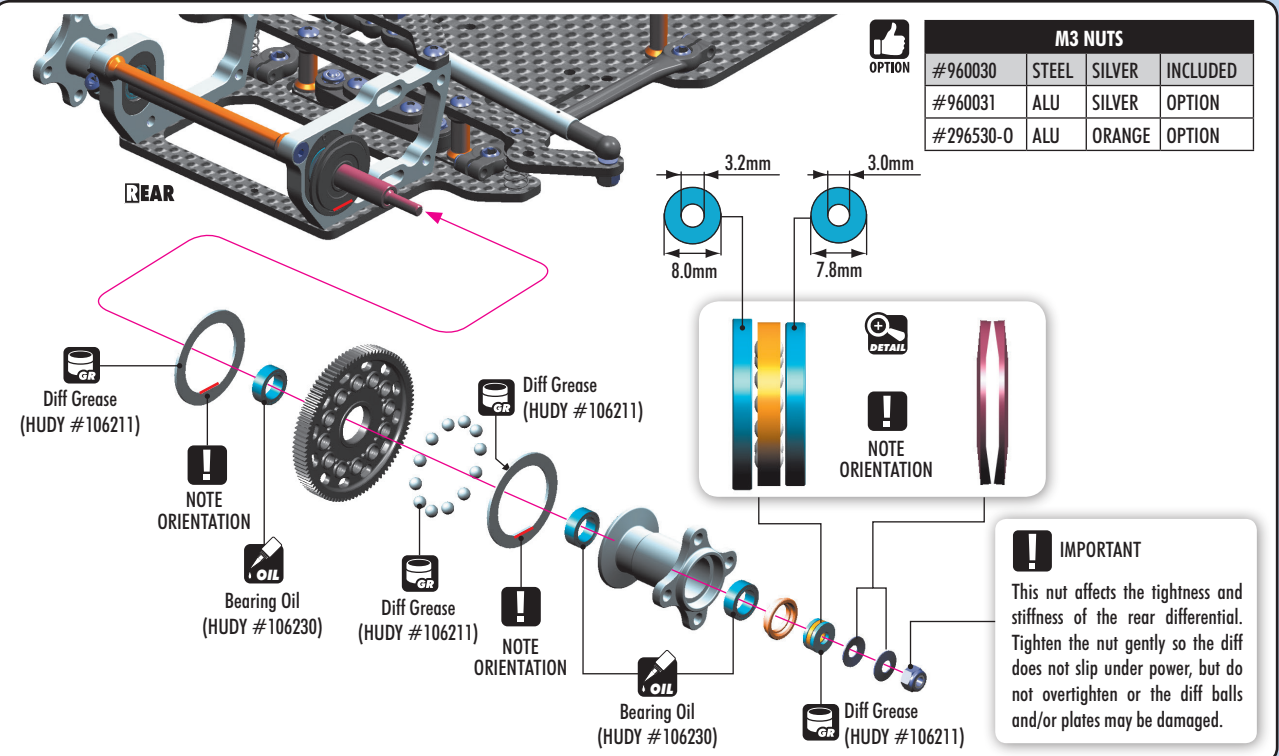

SET-UP BOOK

DIFFERENTIAL

5. SHOCK ABSORBER



SHOCK SPRINGS		
#378092	C=1.5 - SILVER	OPTION
#378093	C=1.8 - GOLD	INCLUDED
#378094	C=2.1 - BLACK	OPTION

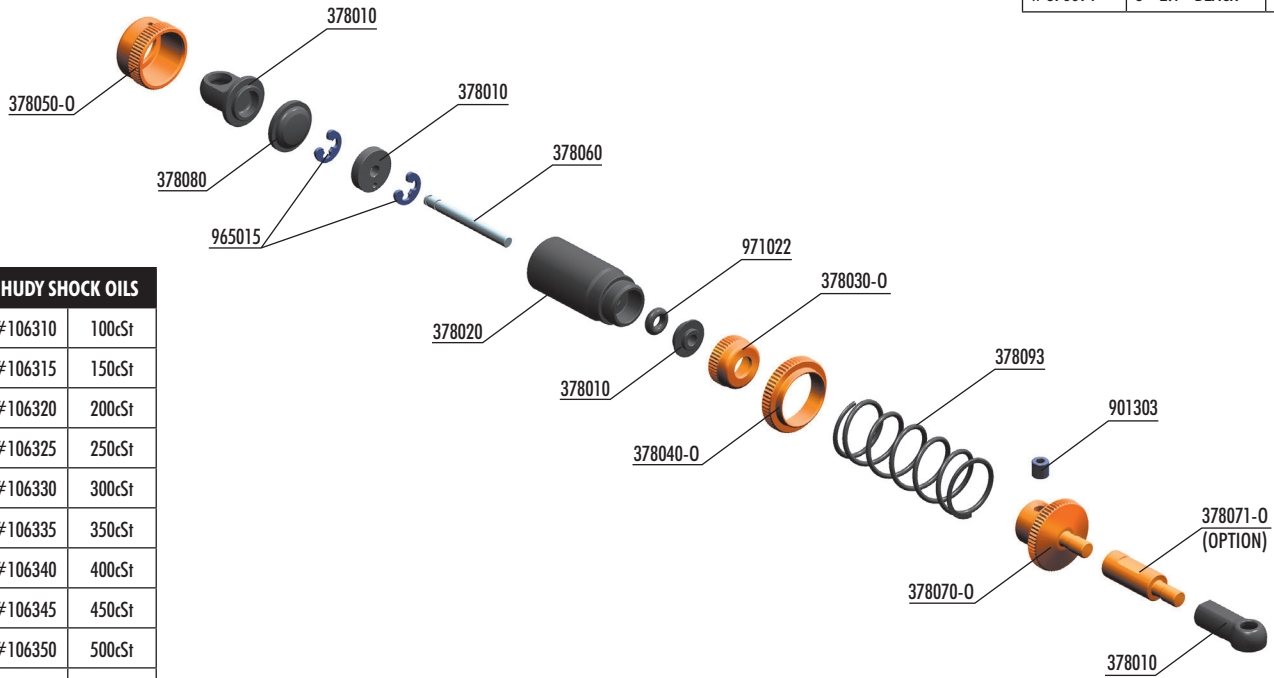

HUDY SHOCK OILS	
#106310	100cSt
#106315	150cSt
#106320	200cSt
#106325	250cSt
#106330	300cSt
#106335	350cSt
#106340	400cSt
#106345	450cSt
#106350	500cSt
#106355	550cSt
#106360	600cSt
#106365	650cSt
#106370	700cSt
#106375	750cSt
#106380	800cSt
#106390	900cSt
#106410	1000cSt
#106420	2000cSt



- 378000 SHOCK ABSORBER SET
- 378010 COMPOSITE SHOCK PARTS - FRAME
- 378020 ALU THREADED SHOCK BODY - HARDCOATED
- 378030-0 ALU SHOCK BODY CAP - LOWER - ORANGE
- 378040-0 ALU SHOCK ADJUSTABLE COLLAR - ORANGE
- 378050-0 ALU SHOCK BODY CAP - UPPER - ORANGE
- 378060 SHOCK SHAFT
- 378070-0 ALU SHOCK SPRING COLLAR - ORANGE
- 378071-0 ALU SHOCK ADAPTER - ORANGE (OPTION)
- 378080 SHOCK RUBBER MEMBRANE (2)
- 378093 SHOCK SPRING - GOLD
- 901303 HEX SCREW SB M3x3 (10)
- 965015 E-CLIP 1.5 (10)
- 971022 SILICONE O-RING 2x2 (10)



965015
C1.5

Carefully remove the shock piston from the frame, and remove all excess plastic flash.

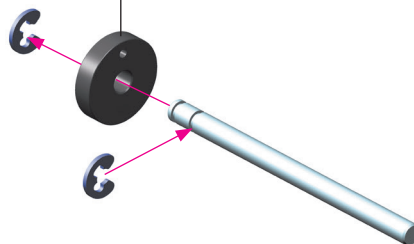

SHOCK ABSORBERS



971022
0 2x2

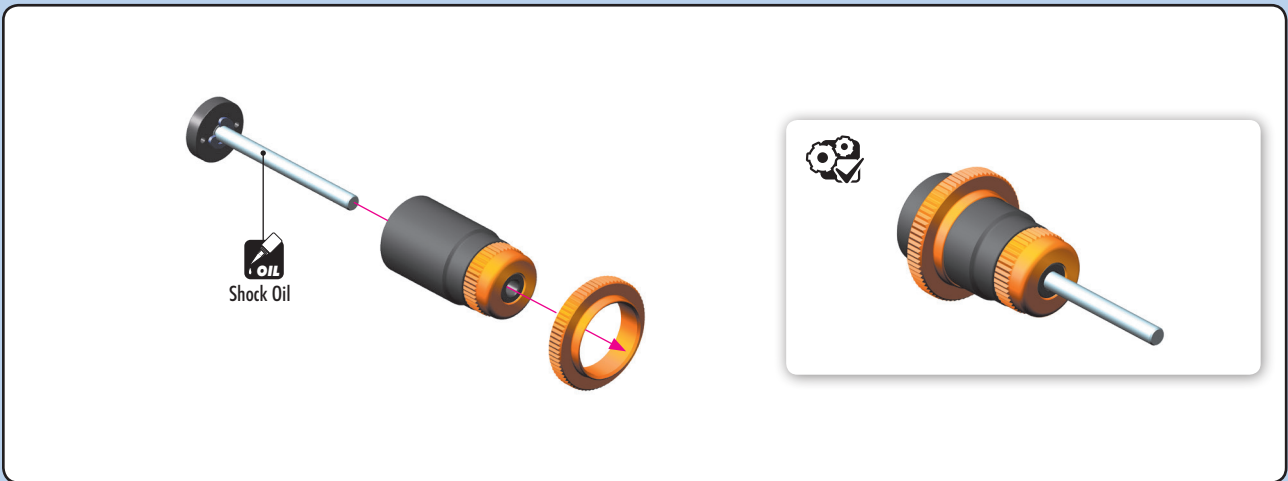
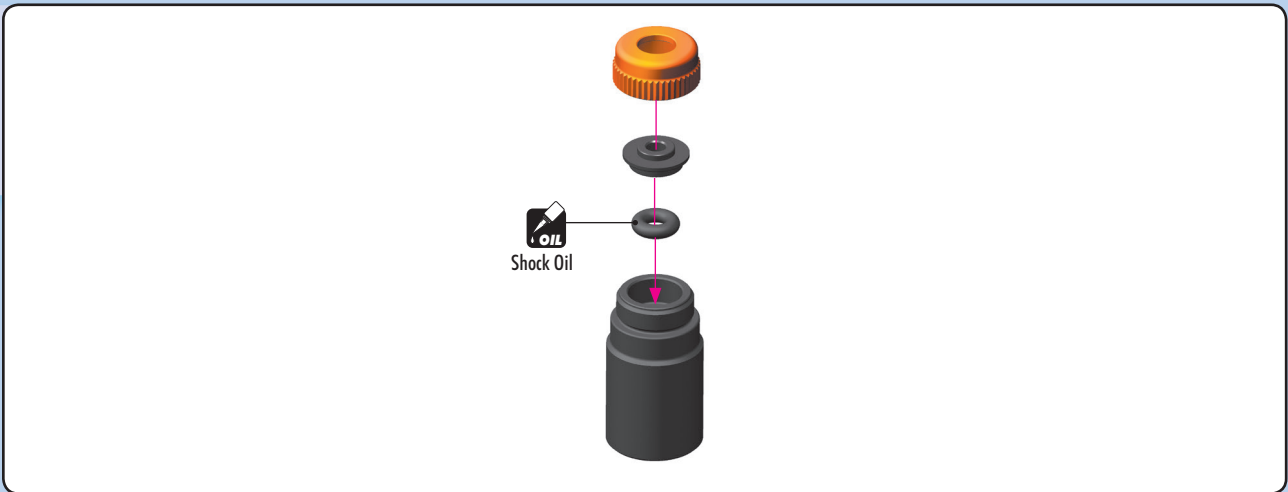

DEFAULT SHOCK SETTING FOR CENTER SHOCK ABSORBER Follow the steps below to set the shock.

- 1** Extend the shock shaft completely. Fill the shock body with the shock oil.
- 2** Move the shock shaft up and down a few times to release the air bubbles trapped beneath the piston.
3~5x UP & DOWN
- 3** Orient the filled shock vertically for several minutes with the shock shaft fully extended. The remaining air bubbles will release.
- 4** Install the shock membrane into the groove in the upper shock cap.
- 5** Gently place the shock cap assembly onto the filled shock body. Excess oil will spill from the shock. Screw the shock cap onto the body by only a few turns, approx. 50%. Excess oil will flow through the hole in the shock cap.
- 6** Gently push the shock shaft completely into the shock body. Excess oil will flow through the hole in the shock cap.
- 7** Keep the shock shaft pushed in the shock body and tighten the shock cap completely.
Tighten the cap fully but do not overtighten or the rubber membrane may be damaged. Make sure that there is no oil leakage after the cap is tightened.

901303
SB M3x3

ALTERNATIVE 1 - SHORT SHOCK (INITIAL SETTING)

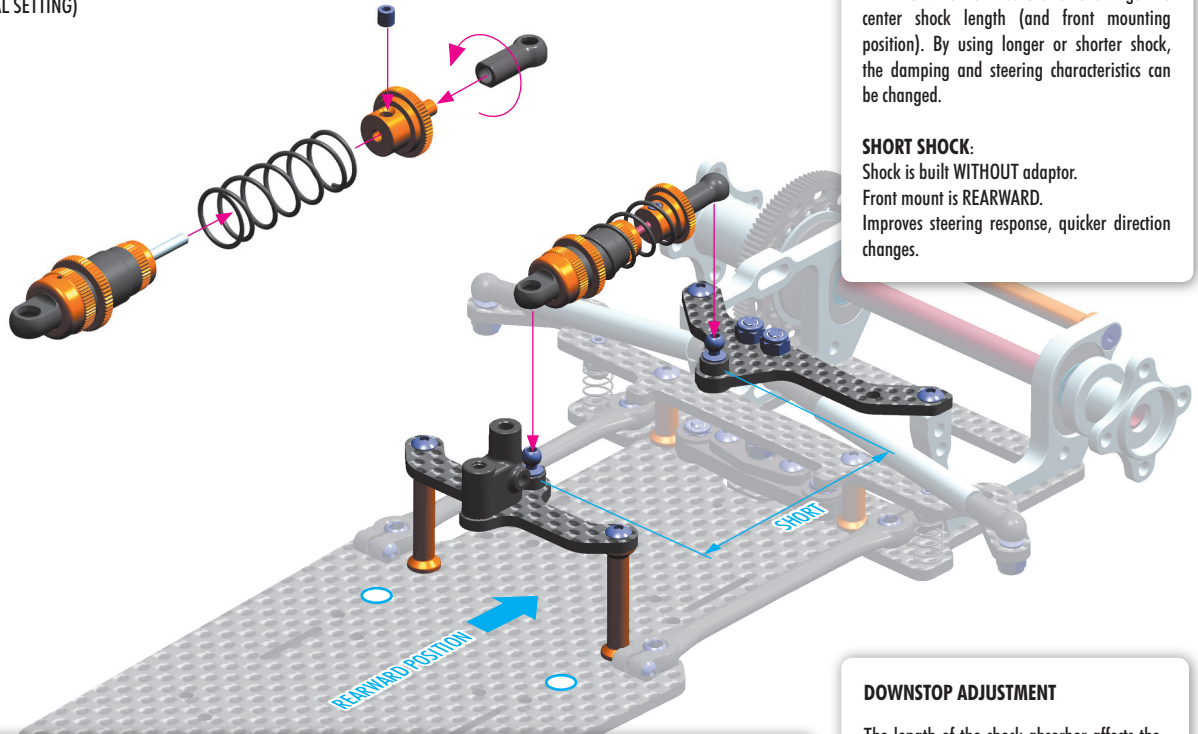

An innovative new feature is to change the center shock length (and front mounting position). By using longer or shorter shock, the damping and steering characteristics can be changed.

SHORT SHOCK:
Shock is built WITHOUT adaptor.
Front mount is REARWARD.
Improves steering response, quicker direction changes.

Press the collar FULLY onto the end of the shock shaft and tighten the M3x3 setscrew.

For initial setting, thread fully.

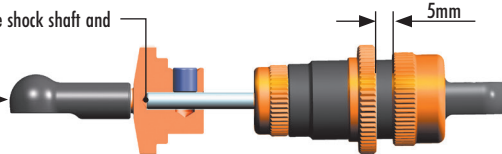

DOWNSTOP ADJUSTMENT

The length of the shock absorber affects the amount of rear downstop. To adjust, thread the ball-joint on or off the threaded post on the bottom spring cap.

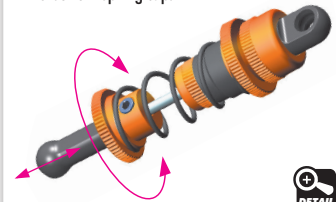

ALTERNATIVE 2 - LONG SHOCK OPTION (OPTIONAL)

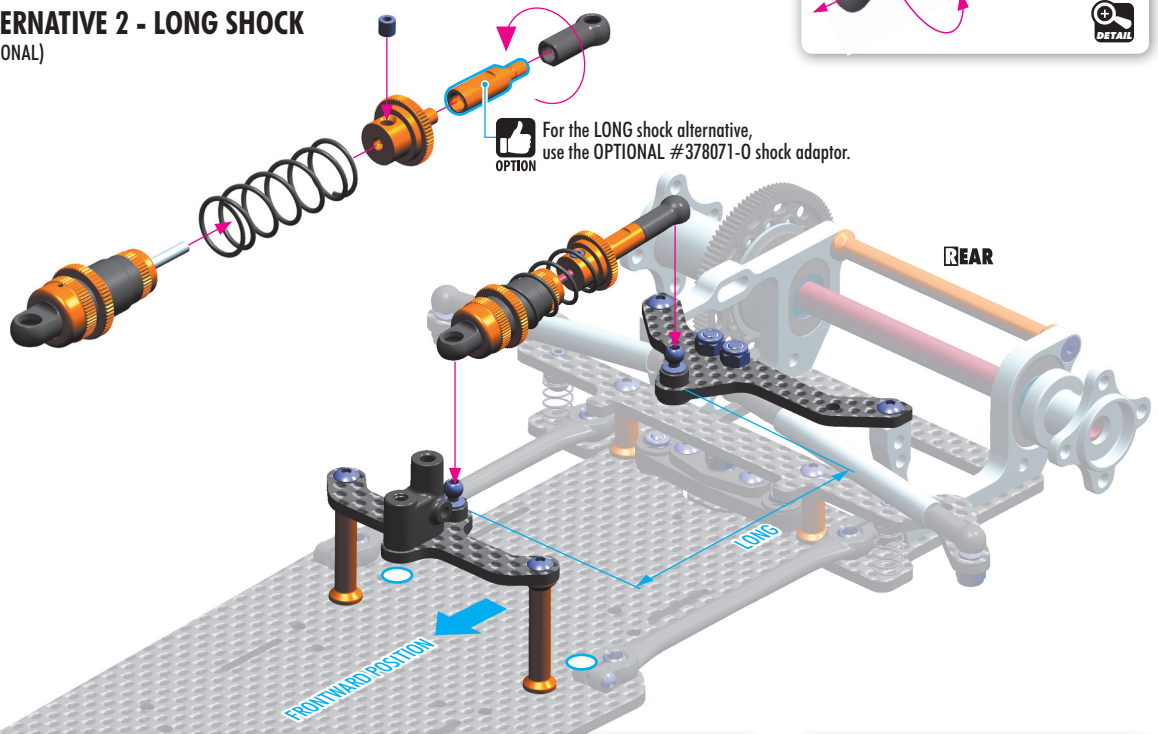

For the LONG shock alternative, use the OPTIONAL #378071-0 shock adaptor.

Press the collar FULLY onto the end of the shock shaft and tighten the M3x3 setscrew.

For initial setting, thread fully.

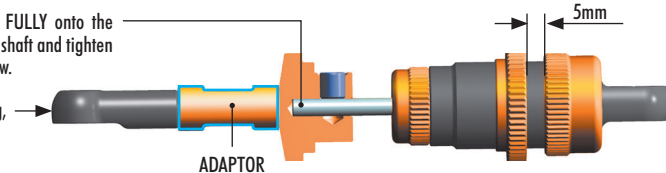

LONG SHOCK:
Shock is built WITH adaptor.
Front mount is FORWARD.
Improves driveability over bumps, improves on-power traction.

SET-UP BOOK
SHOCK DOWNSTOP

6. FINAL ASSEMBLY

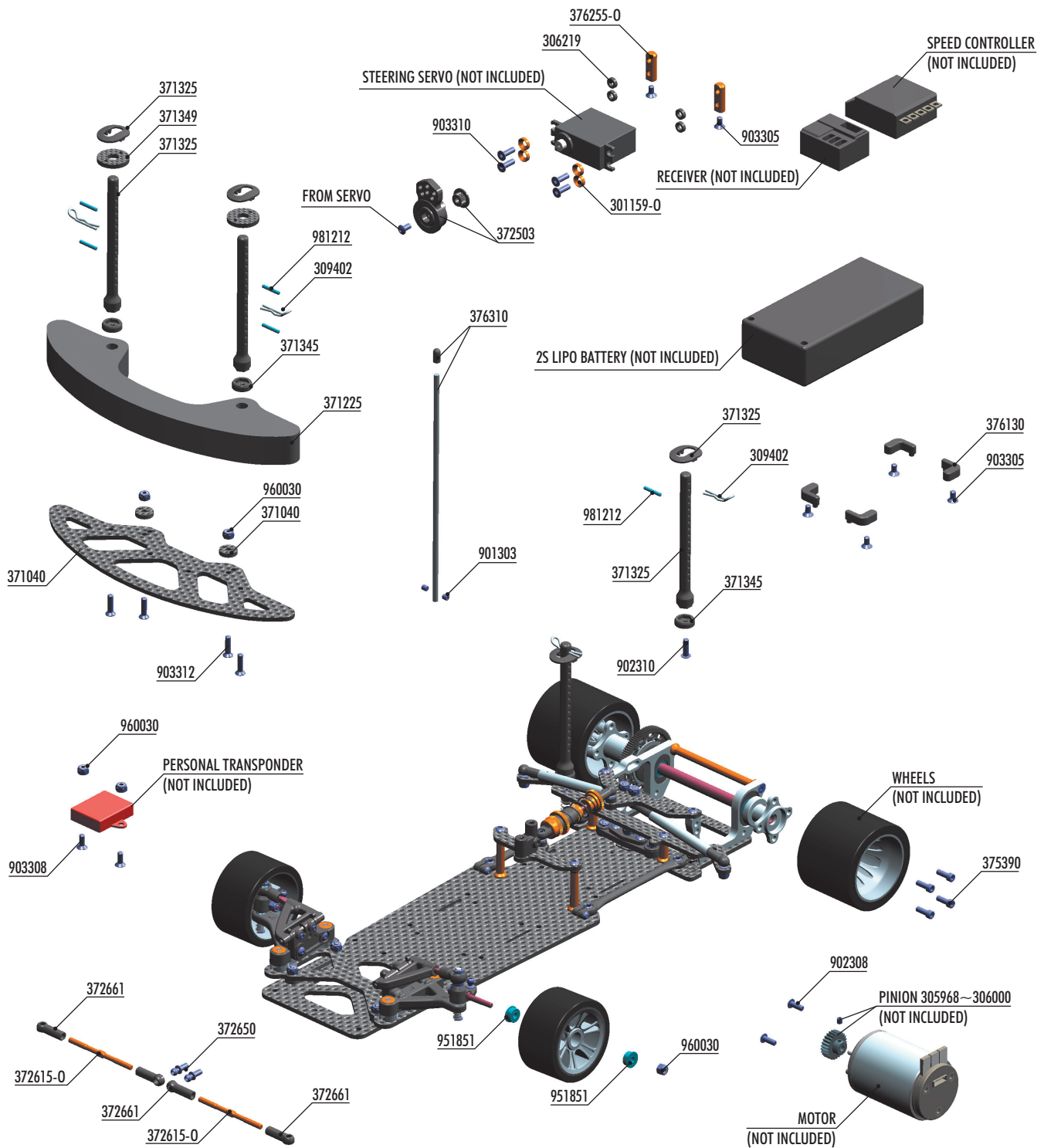

BAG

06

301159-0	ALU COUNTERSUNK SHIM - ORANGE (4)	376130	COMPOSITE LiPo BATTERY BACKSTOP (2)
305968-306000	PINION GEAR HARD COATED 18~50T/64P (OPTION)	376310	FIBERGLASS SOLID ANTENNA ROD + CAP
306219	COMPOSITE SET OF SERVO SHIMS (4)		
309402	BODY CLIP FOR 6MM BODY POST (4)	901303	HEX SCREW SB M3x3 (10)
371040	X10 GRAPHITE 2.5MM FRONT BUMPER & SHIMS - V2	902308	HEX SCREW SH M3x8 (10)
371225	X10 FOAM BUMPER	902310	HEX SCREW SH M3x10 (10)
371325	X10 COMPOSITE BODY POST (2)	903305	HEX SCREW SFH M3x5 (10)
371345	COMPOSITE SHIM FOR BODY POST (2)	903308	HEX SCREW SFH M3x8 (10)
371349	GRAPHITE 2.5MM SHIM FOR 6MM BODY POST (2)	903310	HEX SCREW SFH M3x10 (10)
372503	COMPOSITE SERVO SAVER - X-STIFF - SET - V2	903312	HEX SCREW SFH M3x12 (10)
372615-0	ALU ADJ. TURNBUCKLE M3x50 MM - SWISS 7075 T6 - ORANGE (2)	951851	BALL-BEARING 1/8" x 5/16" x 9/64" FLANGED (2)
372650	BALL-END 4.2MM - THREADED - HUDY SPRING STEEL™ (2)	960030	NUT M3 (10)
372661	COMPOSITE STEERING BALL-JOINT 4.2 MM OPEN (4)	981212	PIN 2x12 (10)
375390	ALU HEX SCREW M3x8 FOR REAR WHEELS (6)		
376255-0	X10 ALU SERVO MOUNT - ORANGE (2)		

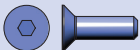

903310
SFH M3x10

IO

306219
SHIM 3x6x2



ACKERMANN

ALTERNATIVE 1 - MID size servo (INITIAL SETTING)

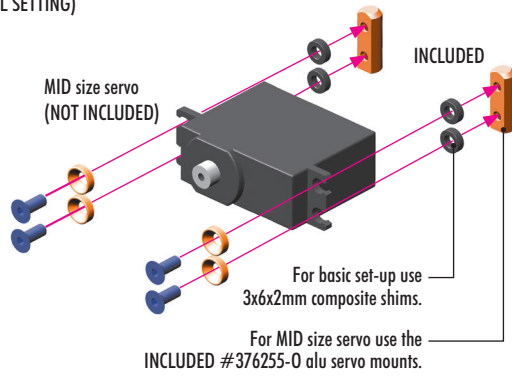

ALTERNATIVE 2 - STANDARD size servo (OPTIONAL)

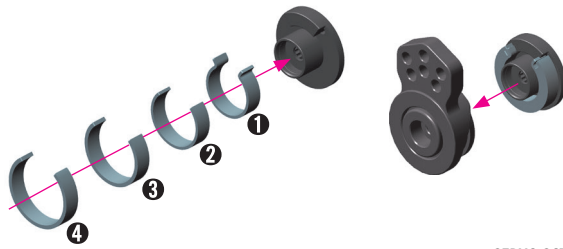
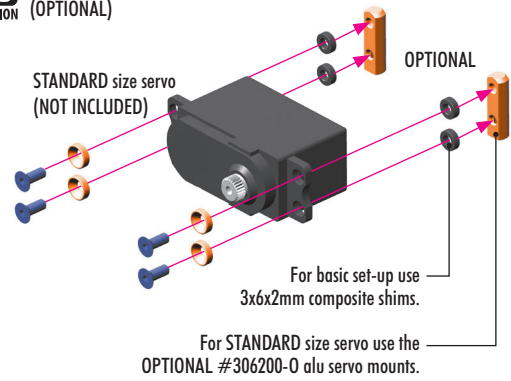

SERVO SCREW (NOT INCLUDED)

NOTE ORIENTATION



Note the orientation of servo saver when servo is in neutral.

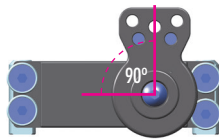

INITIAL SETTING



Use the adapter that matches your servo.

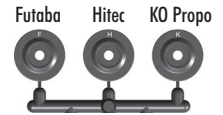

903305
SFH M3x5

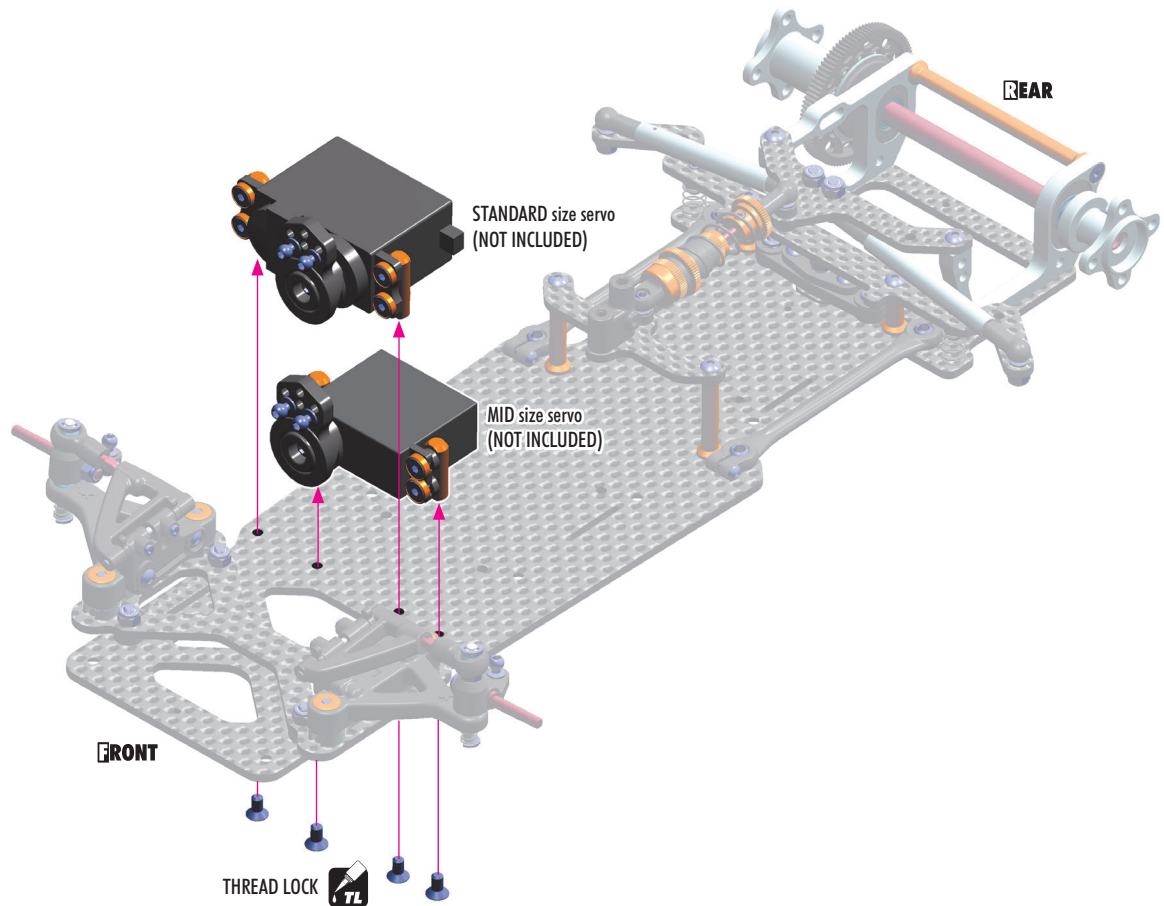

ACKERMANN

FINAL ASSEMBLY

2x

35.7mm

35.7mm

Left thread **LEFT**

RIGHT Left thread

2x

! NOTE ORIENTATION

Note groove position

! NOTE ORIENTATION

Note groove position



902310
SH M3x10



981212
P 2x12

2x

REAR



903308
SFH M3x8



903312
SFH M3x12



960030
N M3

2x

3x12mm

3x8mm

3x12mm

FRONT

REAR

3x12mm

The bodies for 1/10 pan cars are available in different lengths. The bumper position depends on the length of the body.

INITIAL SETTING



981212
P 2x12

2x L=R

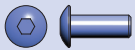
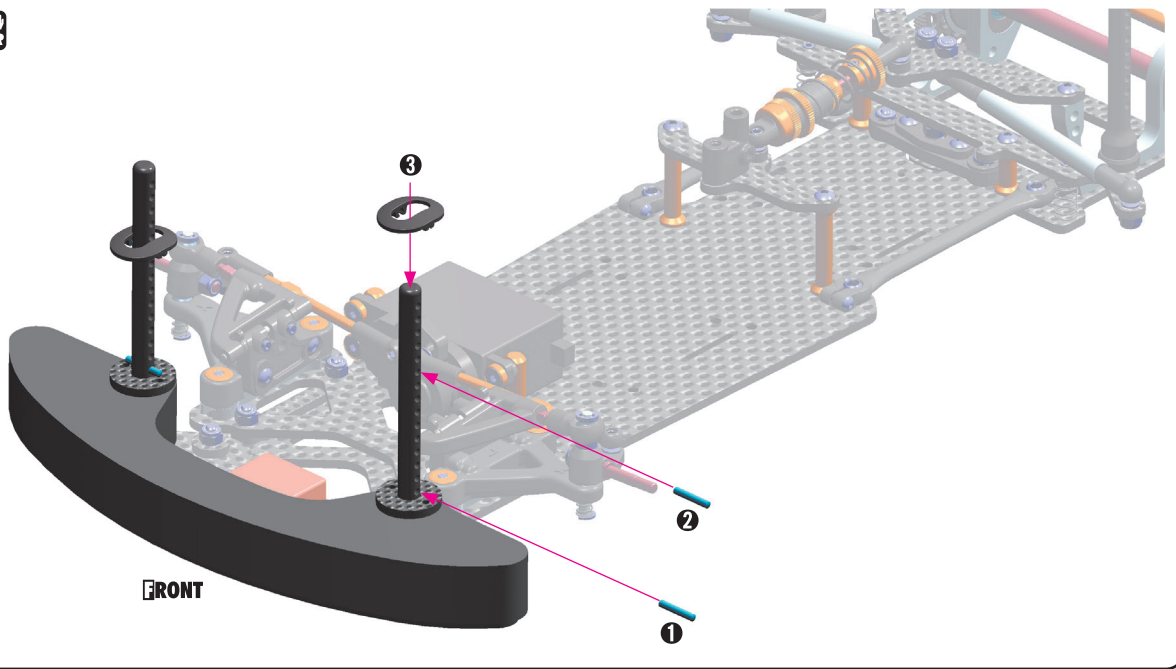

902308
SH M3x8

MOTOR (NOT INCLUDED)

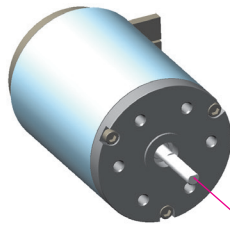

PINION (NOT INCLUDED)



PINION GEARS ALU HARDCOATED

#305968	18T / 64P	OPTION
#305969	19T / 64P	OPTION
#305970	20T / 64P	OPTION
#305971	21T / 64P	OPTION
#305972	22T / 64P	OPTION
#305973	23T / 64P	OPTION
#305974	24T / 64P	OPTION
#305975	25T / 64P	OPTION
#305976	26T / 64P	OPTION
#305977	27T / 64P	OPTION
#305978	28T / 64P	OPTION
#305979	29T / 64P	OPTION
#305980	30T / 64P	OPTION
#305981	31T / 64P	OPTION
#305982	32T / 64P	OPTION
#305983	33T / 64P	OPTION
#305984	34T / 64P	OPTION
#305985	35T / 64P	OPTION
#305986	36T / 64P	OPTION
#305987	37T / 64P	OPTION
#305988	38T / 64P	OPTION
#305990	40T / 64P	OPTION
#305991	41T / 64P	OPTION
#305992	42T / 64P	OPTION
#305994	44T / 64P	OPTION
#305996	46T / 64P	OPTION
#305997	47T / 64P	OPTION
#305998	48T / 64P	OPTION
#306000	50T / 64P	OPTION

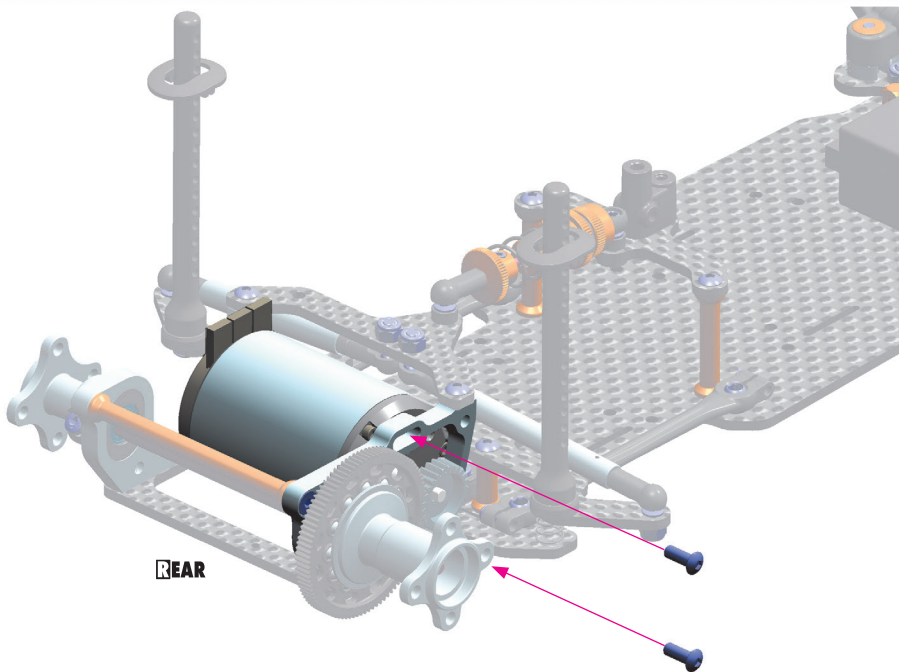

GEAR MESH

Adjust the gear mesh so there is appropriate space between the spur gear and pinion teeth. There should be a very small amount of freeplay.

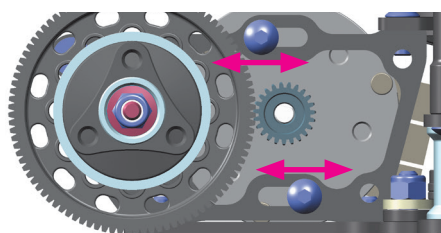

GEAR RATIO

FINAL ASSEMBLY



903305
SFH M3x5

ELECTRONICS CONFIGURATION:

REARWARD POSITION (INITIAL POSITION)

When inserting or removing batteries, remove graphite plate for mounts and antenna holder.

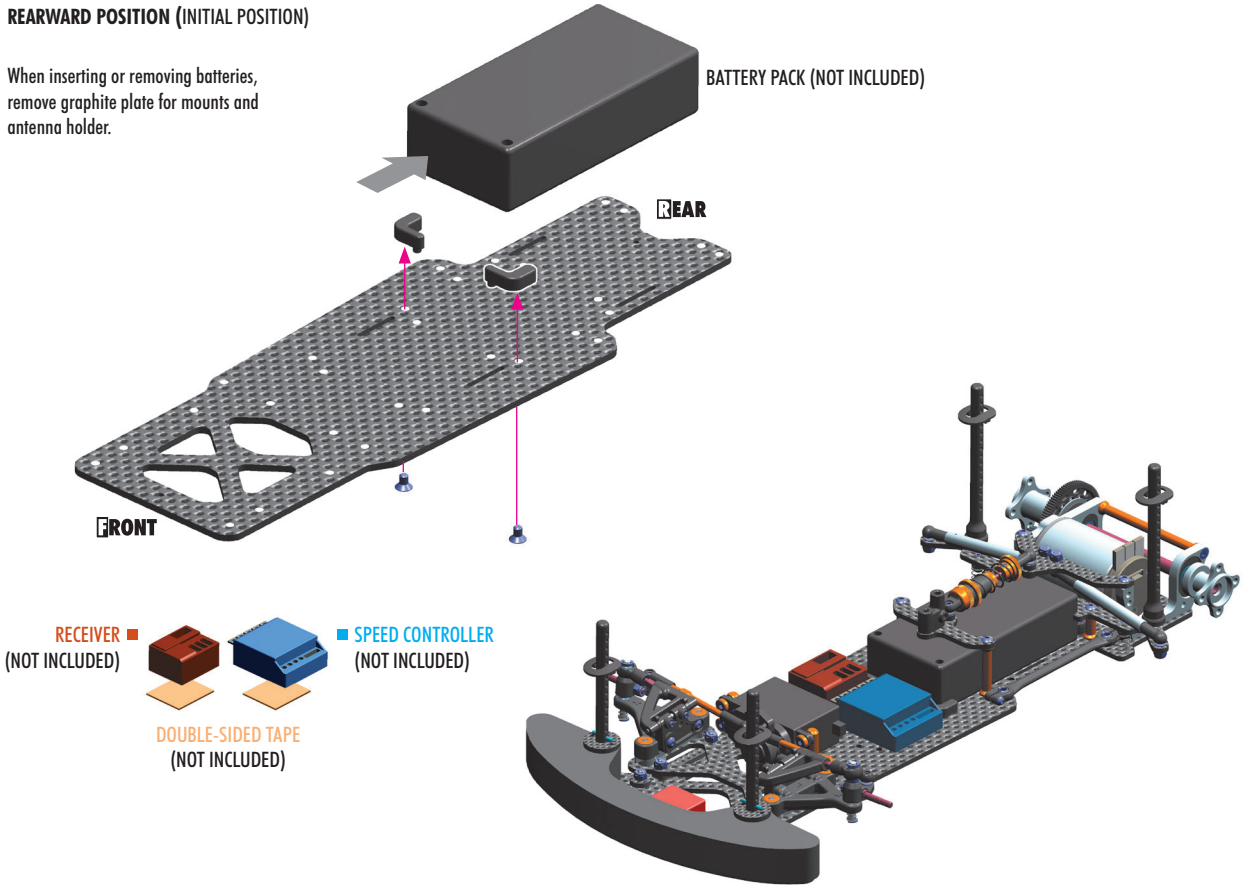

903305
SFH M3x5

ELECTRONICS CONFIGURATION:

FORWARD POSITION

When inserting or removing batteries, remove graphite plate for mounts and antenna holder.

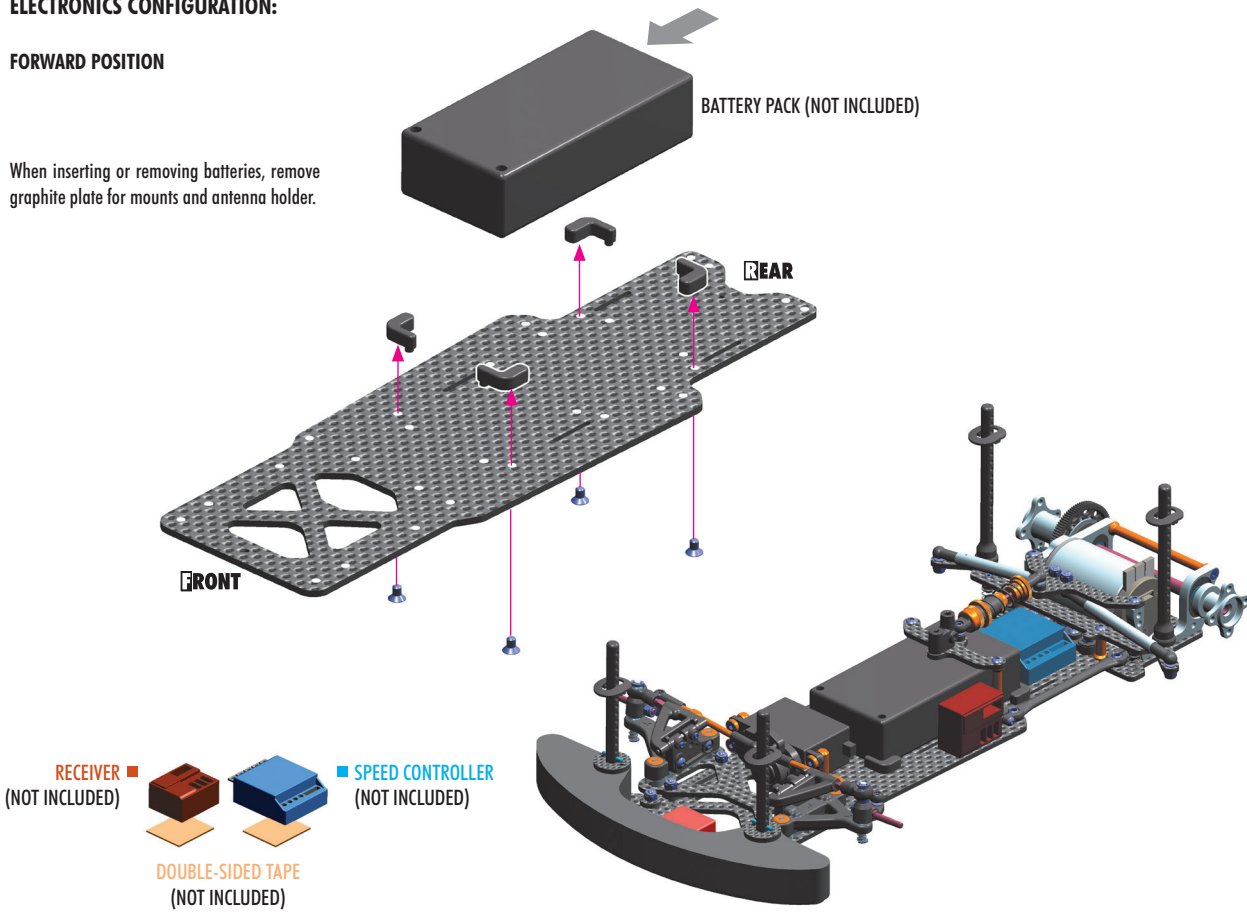

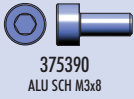

375390
ALU SCH M3x8



901304
SB M3x4



951851
BB 1/8"x5/16"x9/64"



960030
N M3



OPTION

M3 NUTS			
#960030	STEEL	SILVER	INCLUDED
#960031	ALU	SILVER	OPTION
#296530-0	ALU	ORANGE	OPTION

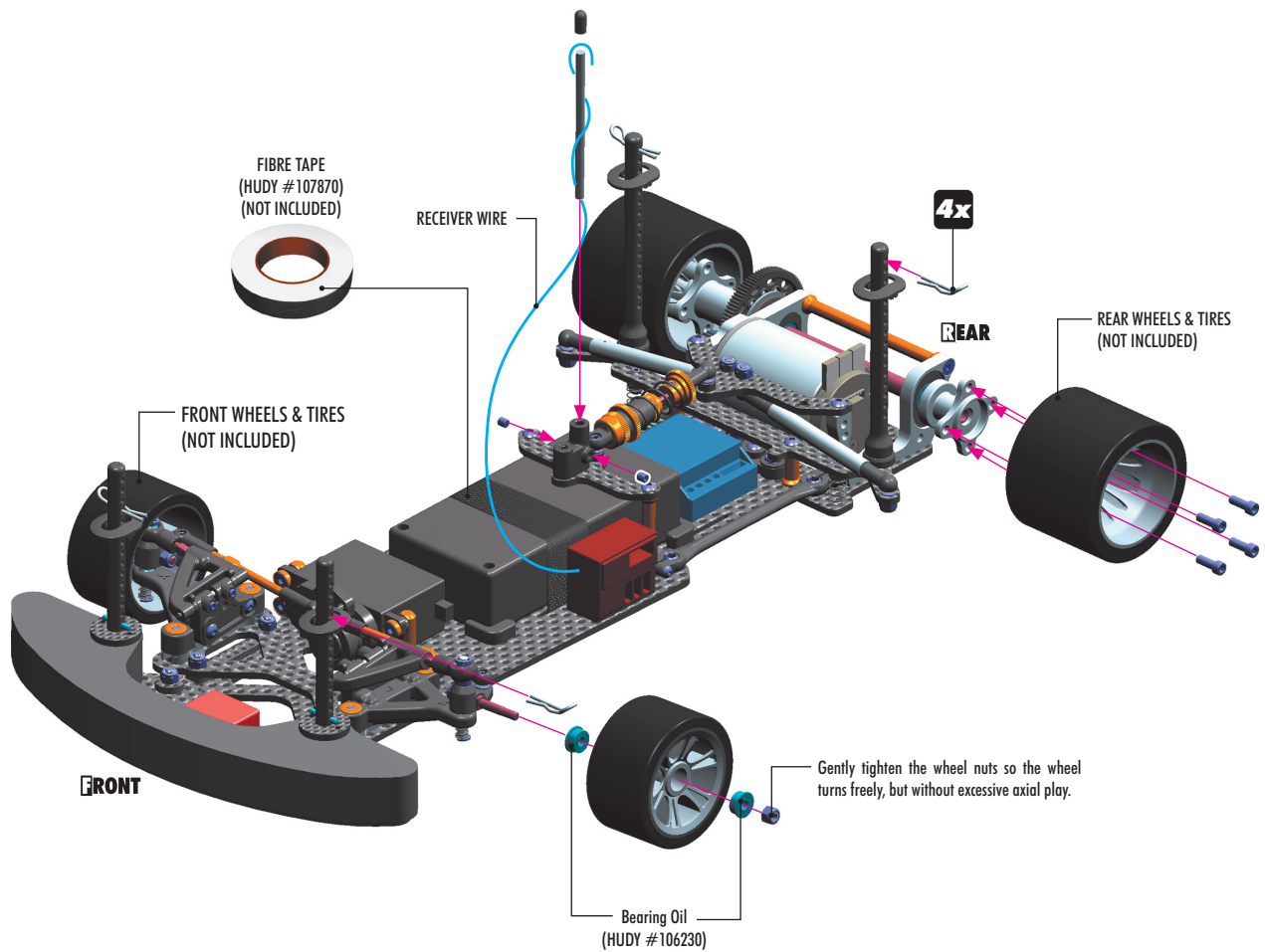

NOT INCLUDED

To ensure that you always have access to the most up-to-date version of the XRAY Set-up Book, XRAY will now be offering only the digital online version at our Web site at www.teamxray.com. By offering this online version instead of including a hardcopy printed version in kits, you will always be assured of having the most current updated version. Set-up Book features the T-bar version of the XII. However, the majority of all set-up adjustments and theory are the same; we strongly recommend that you read and understand the Set-up Book completely.

www.teamxray.com

XRAY EUROPE

XRAY, K VÝSTAVISKU 6992, 91101 TRENCIN, SLOVAKIA, EUROPE
PHONE: +421-32-740 11 00, FAX: +421-32-740 11 09, info@teamxray.com

XRAY USA

RC AMERICA, 2030 Century Center Blvd #15, Irving, TX 75062, USA
PHONE: 214-744-2400, FAX: 214-744-2401, xray@rcamerica.com



[/TeamXray](#)



[/TeamXray](#)



[/TeamXray](#)



[/XrayRacing](#)



[/+TeamXrayRC](#)